

A

B

C

D

E

F

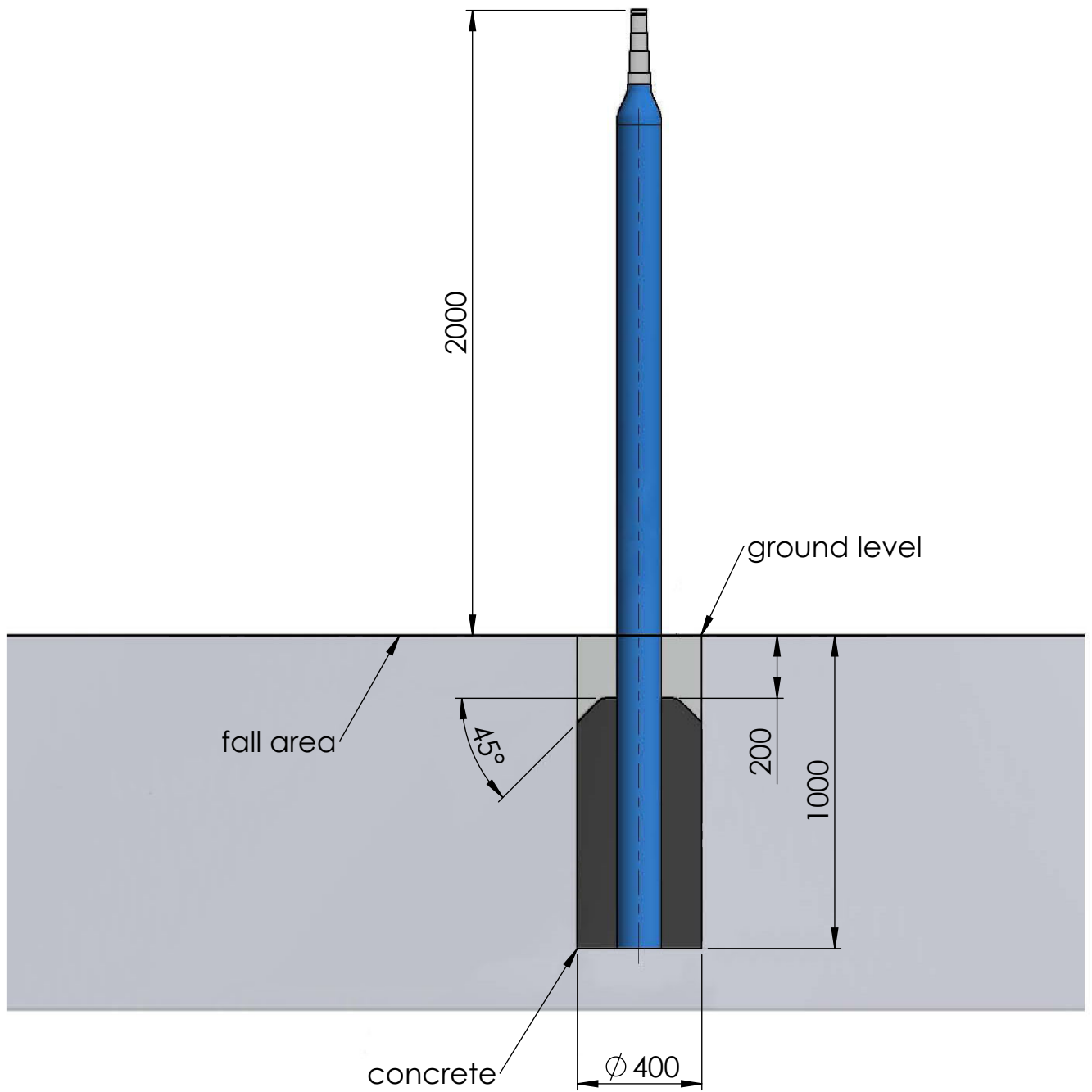

UNLESS OTHERWISE SPECIFIED:  
 DIMENSIONS ARE IN MILLIMETERS  
 WEIGHT ARE IN KILOGRAMM

PART NUMBER / DWG NO.:

GM0723 MF

	NAME	SIGNATURE	DATE	REVISION
DRAWN			05.06.2023	
APPV'D				

DESCRIPTION:

Carousel MONSOON 3



Tiptap<sup>ÖÜ</sup>

MATERIAL:

A4

WEIGHT:

SCALE: 1:1

SHEET 1 OF 3

A

B

C

D

E

F

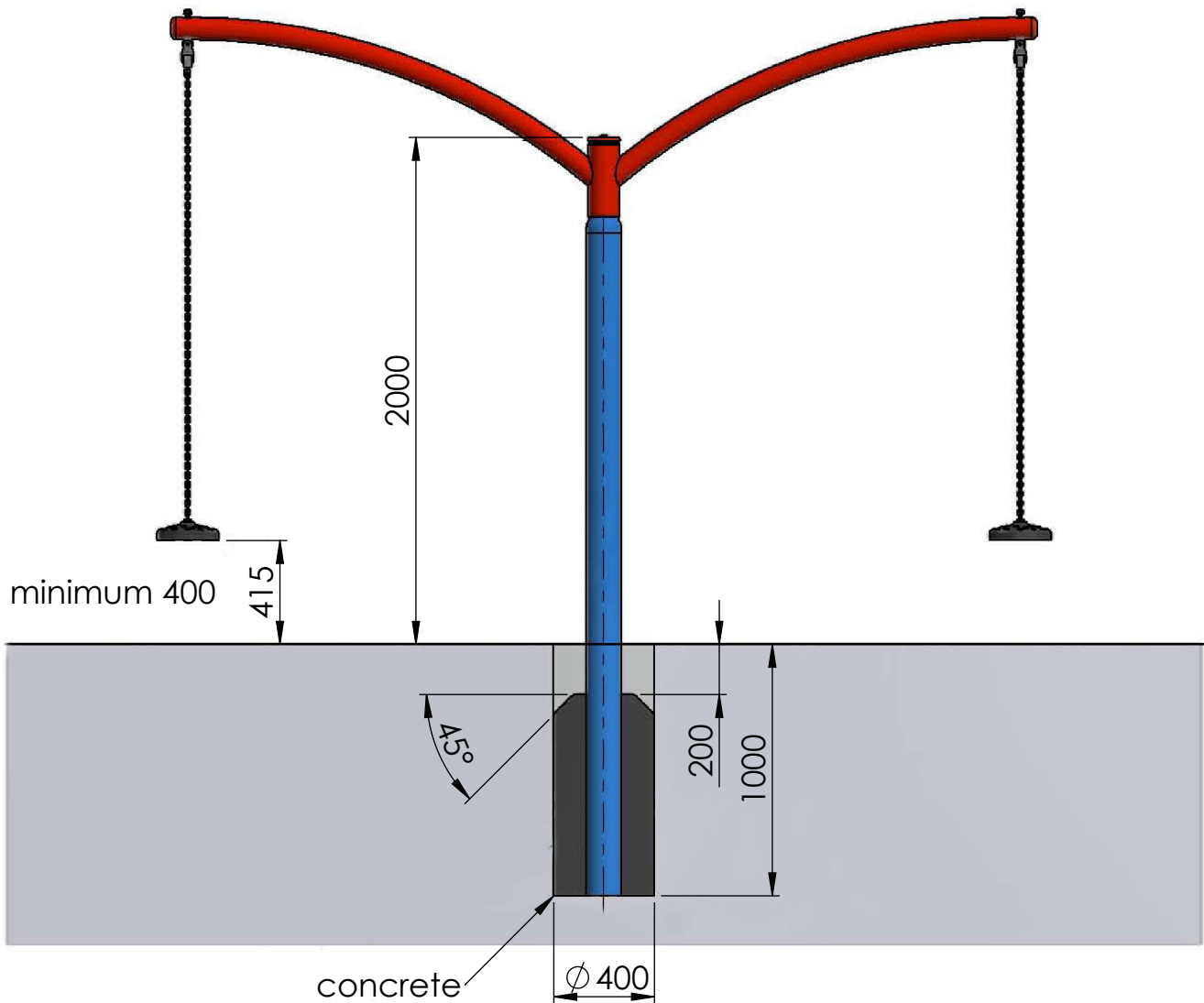

UNLESS OTHERWISE SPECIFIED:  
 DIMENSIONS ARE IN MILLIMETERS  
 WEIGHT ARE IN KILOGRAMM

PART NUMBER / DWG NO.:

GM0723 MF

	NAME	SIGNATURE	DATE	REVISION
DRAWN			05.06.2023	
APPV'D				

DESCRIPTION:

Carousel MONSOON 3



Tiptiptap<sup>ÖÜ</sup>

MATERIAL:

A4

WEIGHT:

SCALE: 1:1

SHEET 2 OF 3

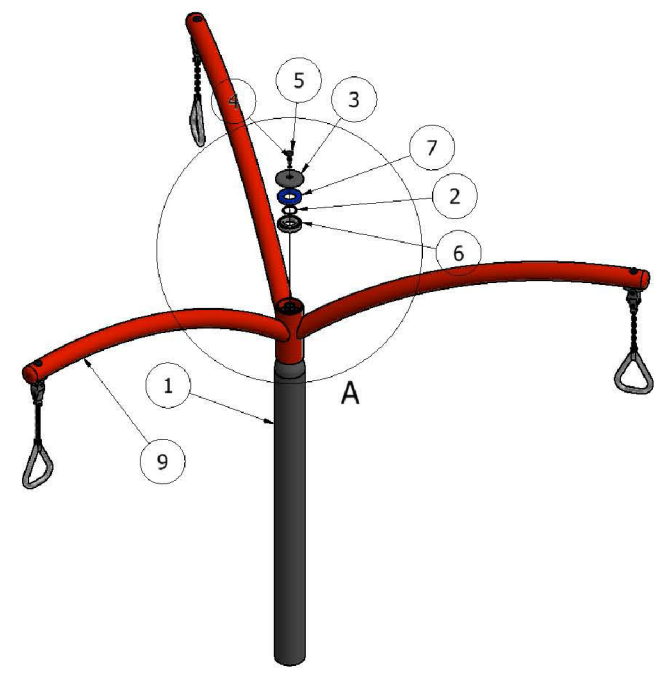
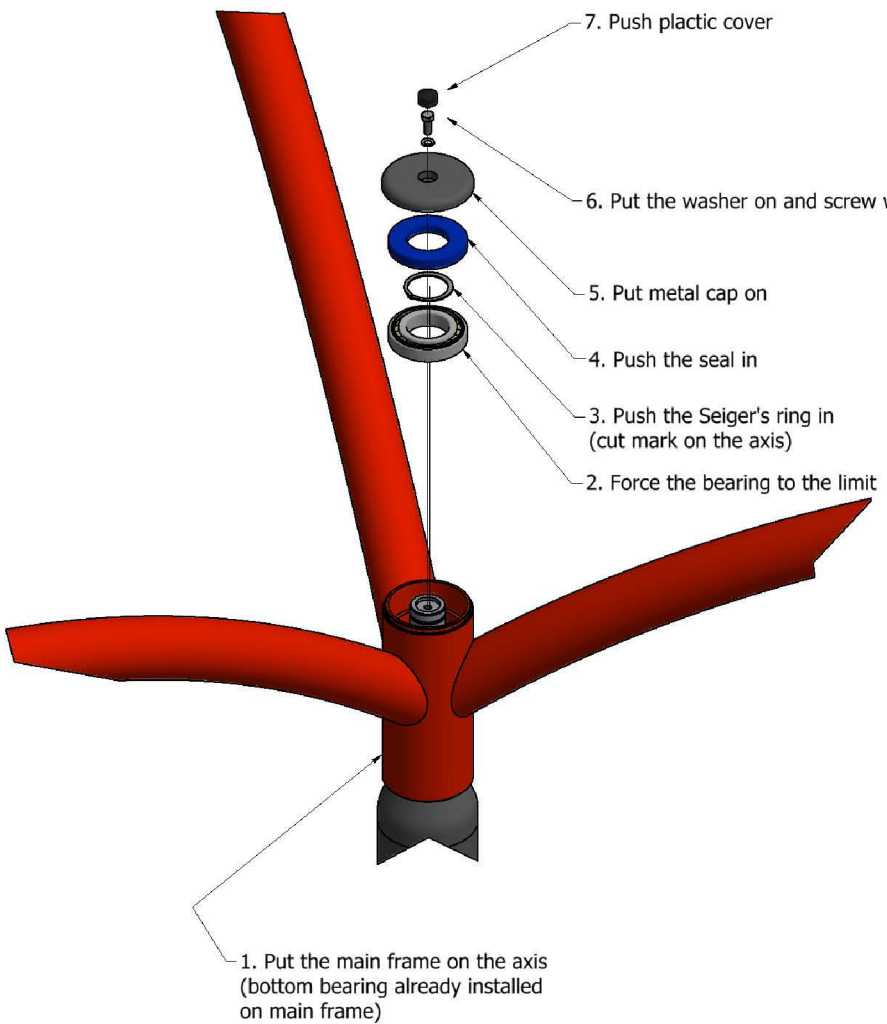

ITEM NO.	QTY.	PART NUMBER	DESCRIPTION
1	1	Foundation post / axis	Foundation post / axis
2	1	Z 50 - PN-81/M85111	Seiger's ring
3	1	57-NS	Metal lid
4	1	M10X25	Bolt
5	1	TZ-PC	Bolt cover
6	1	6310-2RS	Bearing
7	1	Seal 110-50	Seal 110-50
8	1	A10 DIN128	Spring washer
9	1	57-RU3	Carousel's arms

UNLESS OTHERWISE SPECIFIED:  
DIMENSIONS ARE IN MILLIMETERS  
WEIGHT ARE IN KILOGRAMM

NAME	SIGNATURE	DATE	REVISION
DRAWN		05.06.2023	
APPV'D			

PART NUMBER / DWG NO.: **GM0723 MF**

DESCRIPTION: **Carousel MONSOON 3**

MATERIAL: \_\_\_\_\_

WEIGHT: \_\_\_\_\_ SCALE: 1:1 SHEET 3 OF 3



**Tiptap** OÜ