

A

B

C

D

E

F

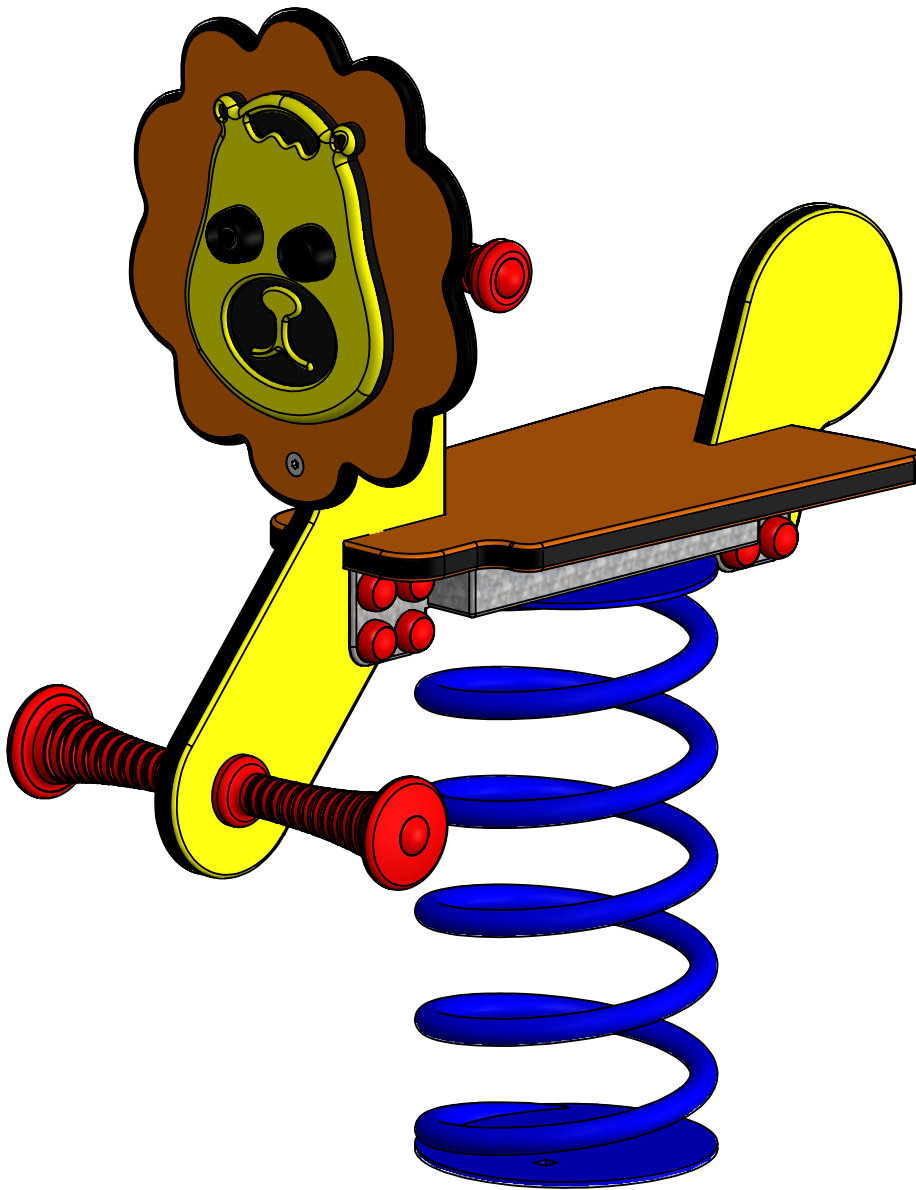

UNLESS OTHERWISE SPECIFIED:
 DIMENSIONS ARE IN MILLIMETERS
 WEIGHT ARE IN KILOGRAMM

PART NUMBER / DWG NO.:

VLO50

	NAME	SIGNATURE	DATE	REVISION
DRAWN	E.Reispere		18.03.2022	
APPV'D				

DESCRIPTION:

Spring swing LION



Tiptiptap⁰⁰

MATERIAL:

metal, plastic

A4

WEIGHT:

SCALE: 1:7

SHEET 1 OF 11

safety area

A

B

C

D

E

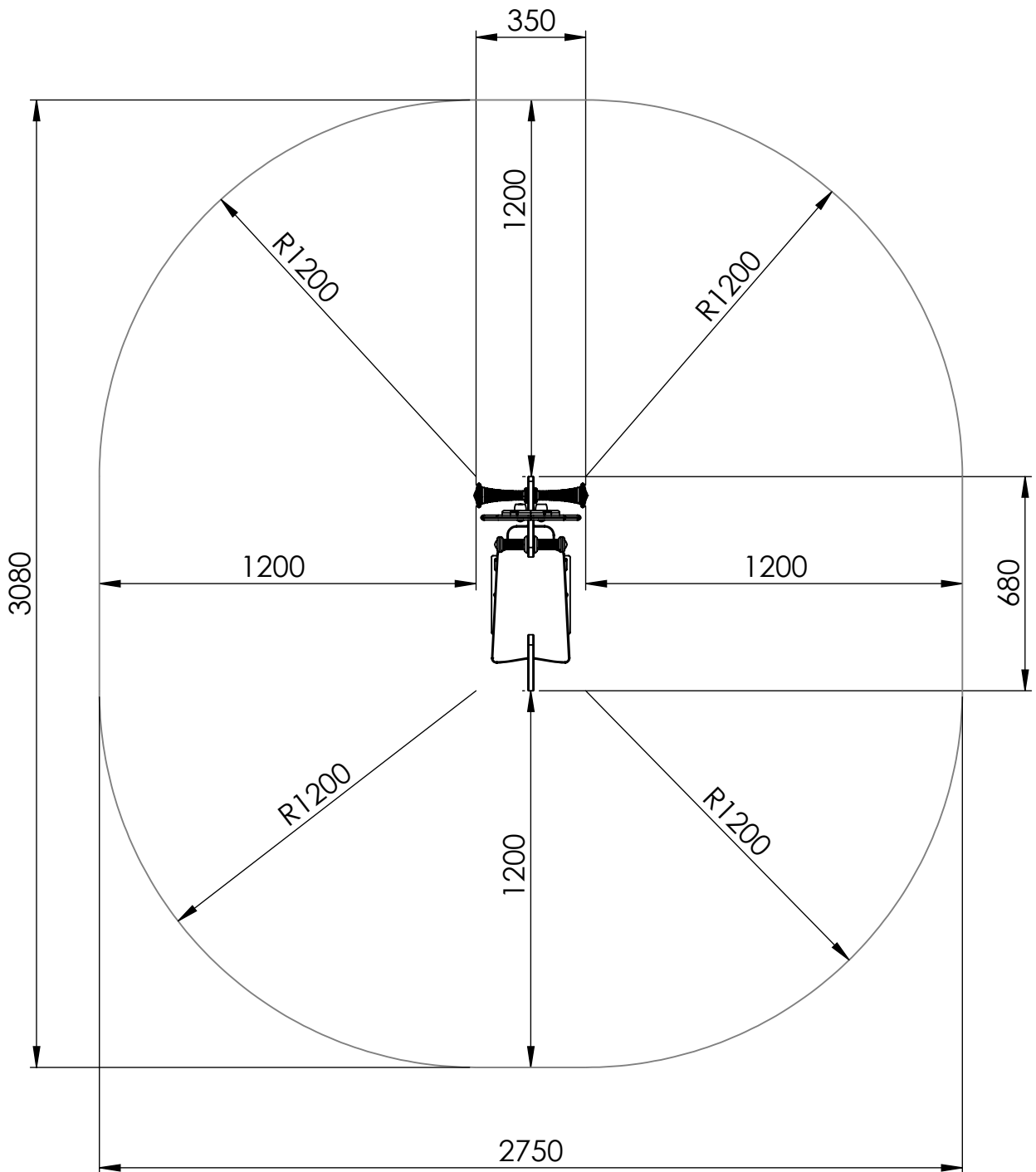

UNLESS OTHERWISE SPECIFIED:
DIMENSIONS ARE IN MILLIMETERS
WEIGHT ARE IN KILOGRAMM

PART NUMBER / DWG NO.:

VLO50

	NAME	SIGNATURE	DATE	REVISION
DRAWN	E.Reispere		18.03.2022	
APPV'D				

DESCRIPTION:

Spring swing LION

F



Tiptiptap ^{OO}

MATERIAL:

metal, plastic

A4

WEIGHT:

SCALE: 1:20

SHEET 2 OF 11

foundation

A

B

C

D

E

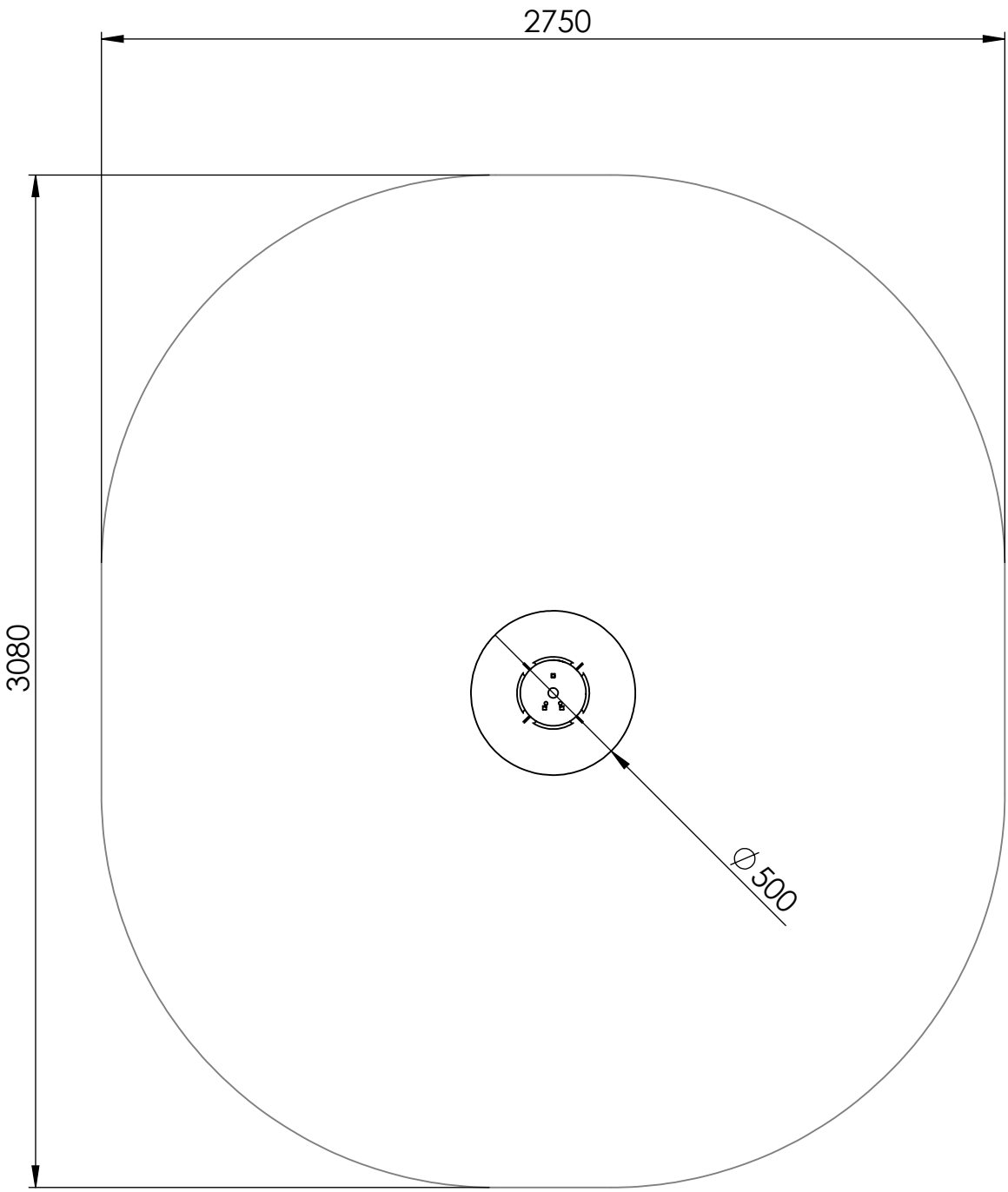

UNLESS OTHERWISE SPECIFIED:
 DIMENSIONS ARE IN MILLIMETERS
 WEIGHT ARE IN KILOGRAMM

PART NUMBER / DWG NO.: **VLO50**

	NAME	SIGNATURE	DATE	REVISION
DRAWN	E.Reispere		18.03.2022	
APPV'D				

DESCRIPTION: **Spring swing LION**



MATERIAL:	metal, plastic	A4
WEIGHT:		SCALE: 1:20
		SHEET 3 OF 11

A

B

C

D

E

F

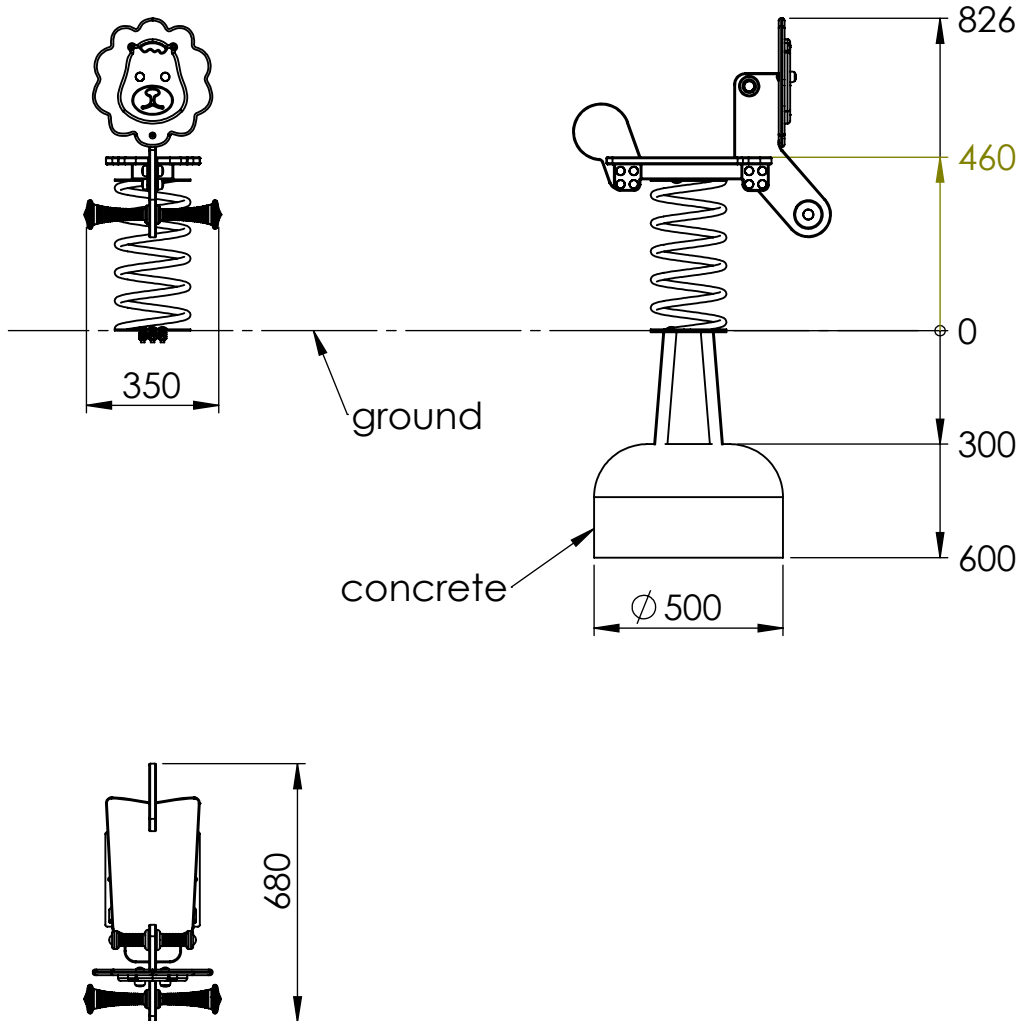

UNLESS OTHERWISE SPECIFIED:
 DIMENSIONS ARE IN MILLIMETERS
 WEIGHT ARE IN KILOGRAMM

PART NUMBER / DWG NO.:

VLO50

	NAME	SIGNATURE	DATE	REVISION
DRAWN	E.Reispere		18.03.2022	
APPV'D				

DESCRIPTION:

Spring swing LION

MATERIAL:

metal, plastic

A4

WEIGHT:

SCALE: 1:20

SHEET 4 OF 11



Tiptiptap OÜ

A

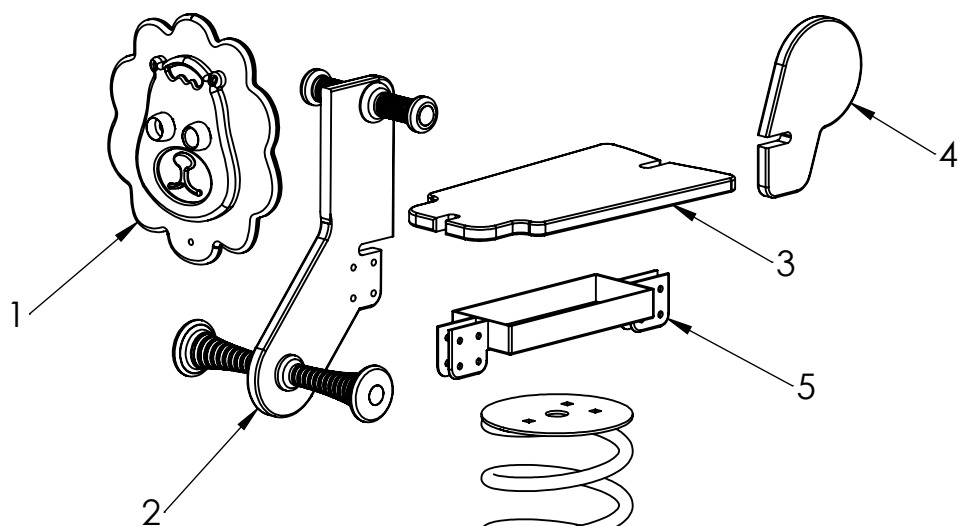

B

C

D

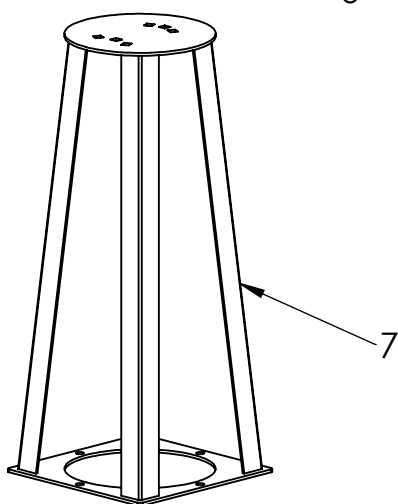

E

ITEM NO.	PART NUMBER	DESCRIPTION
1	VLO50 head	HDPE plastic
2	VLO50 support frame	HDPE plastic
3	VLO50 seat	HDPE plastic
4	tail for spring swing	plastic
5	central console	painted steel
6	spring with spring disk	painted steel
7	ground fixing	galvanized steel

F

UNLESS OTHERWISE SPECIFIED:
DIMENSIONS ARE IN MILLIMETERS
WEIGHT ARE IN KILOGRAMM

PART NUMBER / DWG NO.:

VLO50

	NAME	SIGNATURE	DATE	REVISION
DRAWN	E.Reispere		18.03.2022	
APPV'D				

DESCRIPTION:

Spring swing LION

MATERIAL:

metal, plastic

A4

WEIGHT:

SCALE: 1:10

SHEET 5 OF 11

Tiptiptap^{oü}

A

B

C

D

E

F

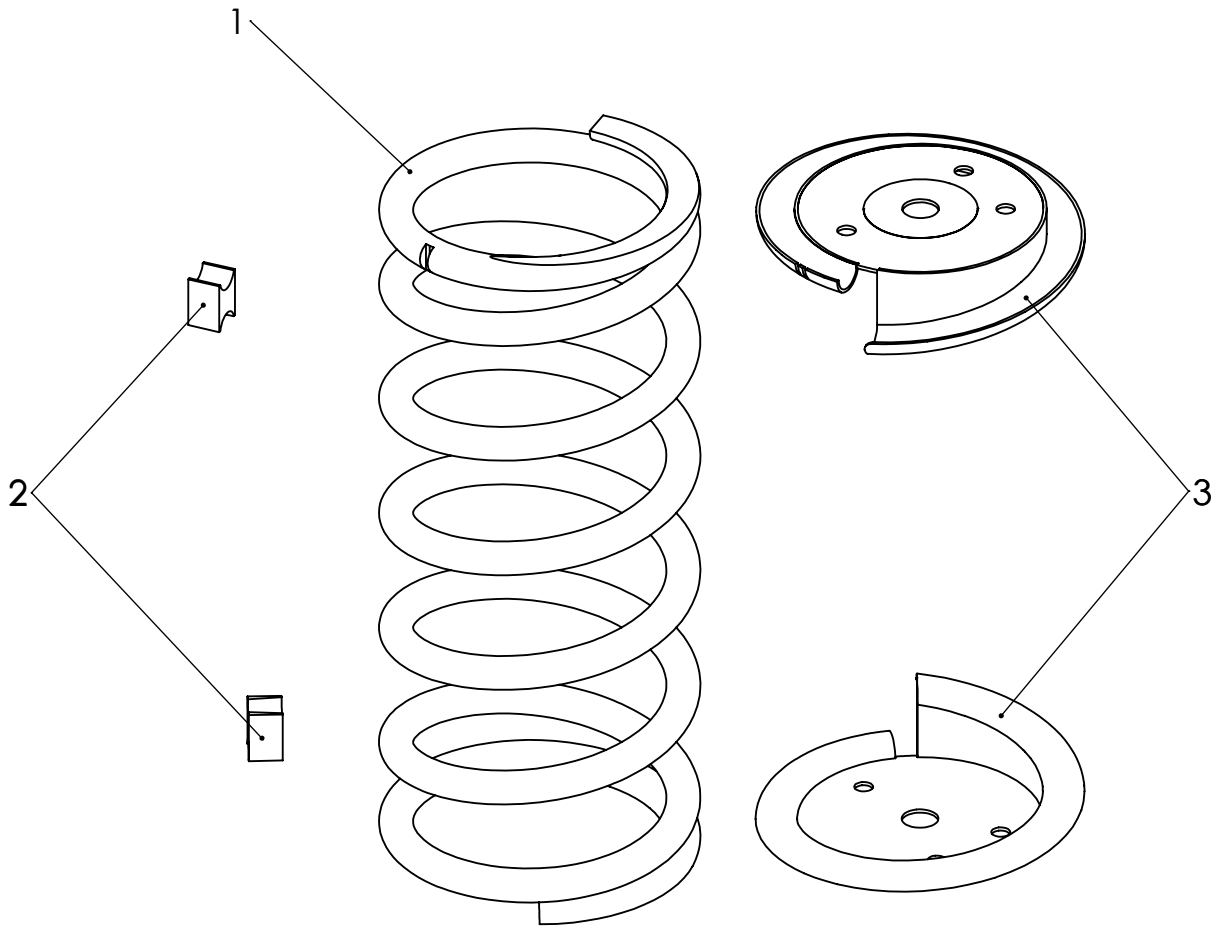

ITEM NO.	PART NUMBER	DESCRIPTION	QTY.
1	spring	painting steel	1
2	distance block	HP plastic	2
3	spring plate	painting steel	2

UNLESS OTHERWISE SPECIFIED:
 DIMENSIONS ARE IN MILLIMETERS
 WEIGHT ARE IN KILOGRAMM

PART NUMBER / DWG NO.:

VLO50

	NAME	SIGNATURE	DATE	REVISION
DRAWN	E.Reispere		18.03.2022	
APPV'D				

DESCRIPTION:

Spring swing LION

MATERIAL:

metal, plastic

A4

WEIGHT:

SCALE: 1:4

SHEET 6 OF 11



Tiptiptap ^{OO}

A

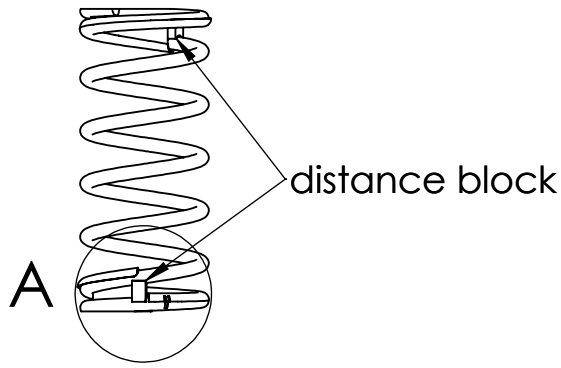

view 1

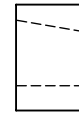
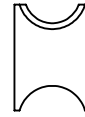
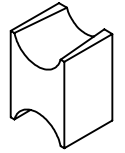

view 2



B

View A

C

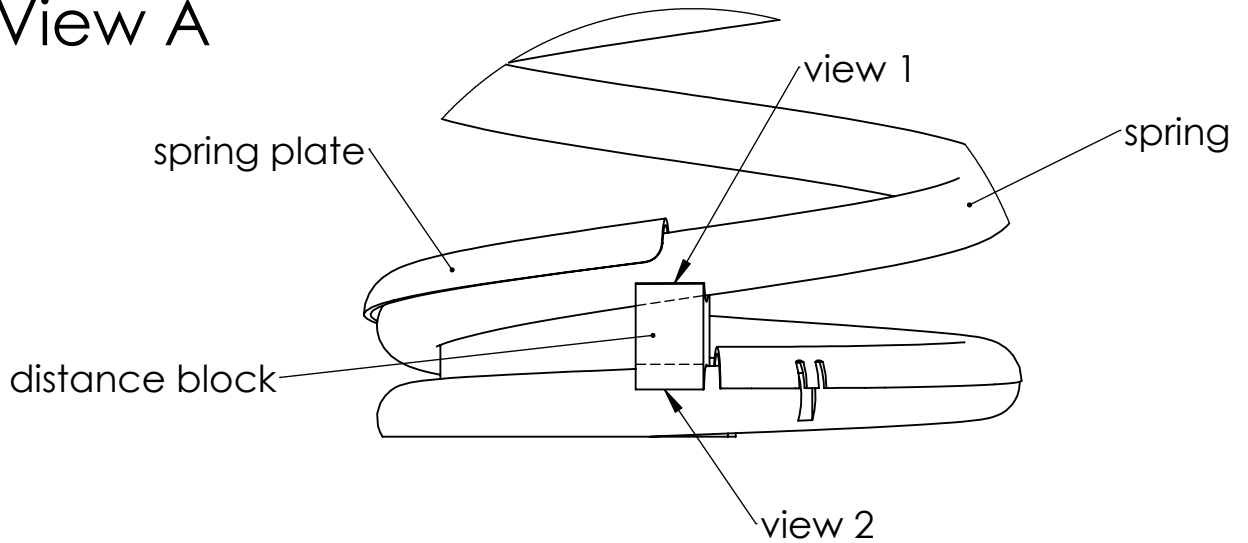

D

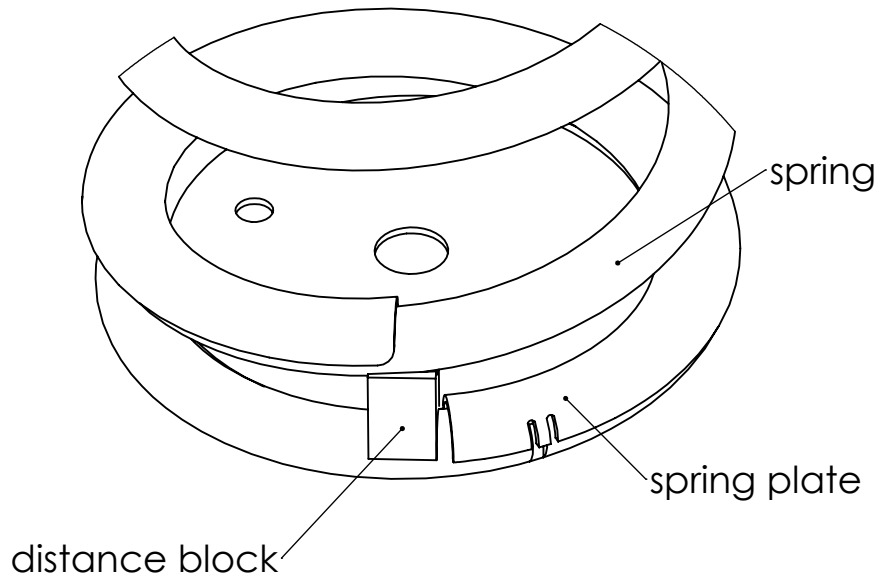

E

F

UNLESS OTHERWISE SPECIFIED:
DIMENSIONS ARE IN MILLIMETERS
WEIGHT ARE IN KILOGRAMM

PART NUMBER / DWG NO.:

VLO50

	NAME	SIGNATURE	DATE	REVISION
DRAWN	E.Reispere		18.03.2022	
APPV'D				

DESCRIPTION:

Spring swing LION

MATERIAL:

metal, plastic

A4

WEIGHT:

SCALE: 1:4

SHEET 7 OF 11



Tiptiptap⁰⁰

A

B

C

D

E

F

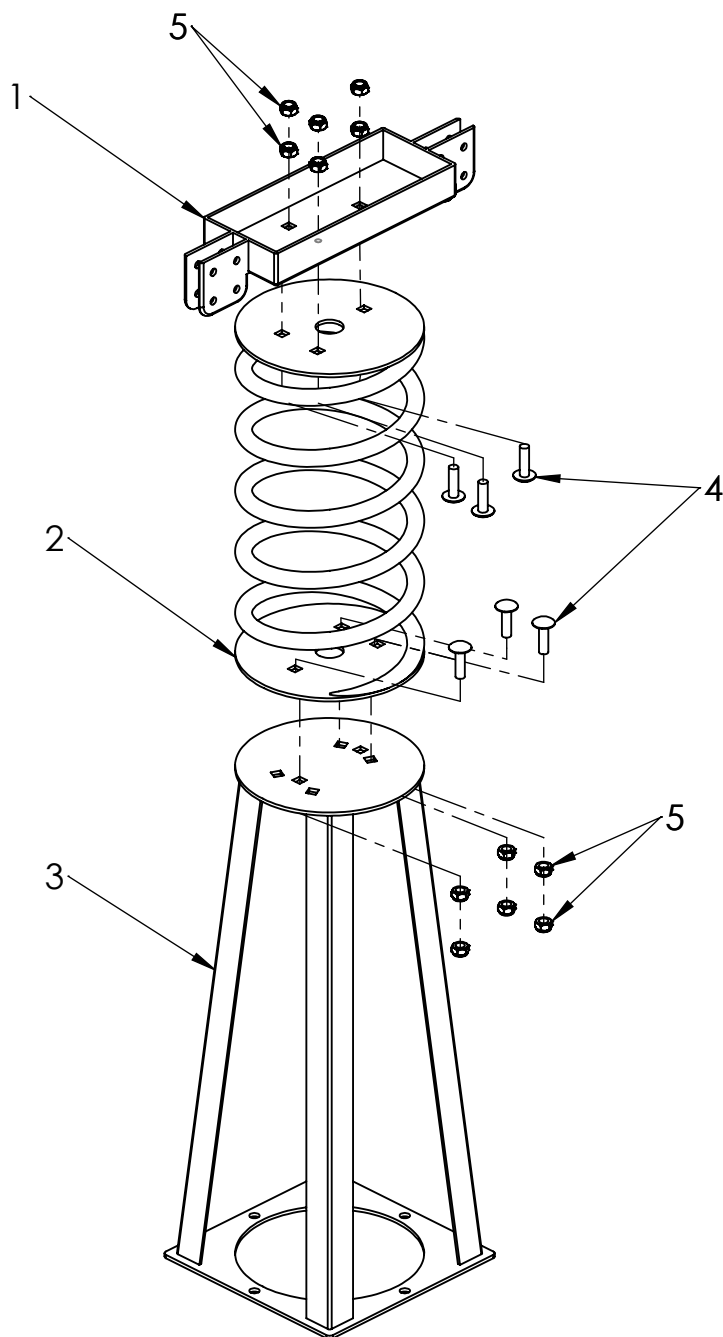

ITEM NO.	PART NUMBER	DESCRIPTION
1	central console	painted steel
2	spring with spring disk	painted steel
3	ground fixing	galvanized steel
4	bolt DIN603 M10x35	galvanized steel
5	nut M10 DIN985	stainless steel

UNLESS OTHERWISE SPECIFIED:
DIMENSIONS ARE IN MILLIMETERS
WEIGHT ARE IN KILOGRAMM

PART NUMBER / DWG NO.:

VLO50

	NAME	SIGNATURE	DATE	REVISION
DRAWN	E.Reispere		18.03.2022	
APPV'D				

DESCRIPTION:

Spring swing LION

MATERIAL:

metal, plastic

A4

WEIGHT:

SCALE: 1:10

SHEET 8 OF 11



Tiptiptap OÜ

A

B

C

D

E

F

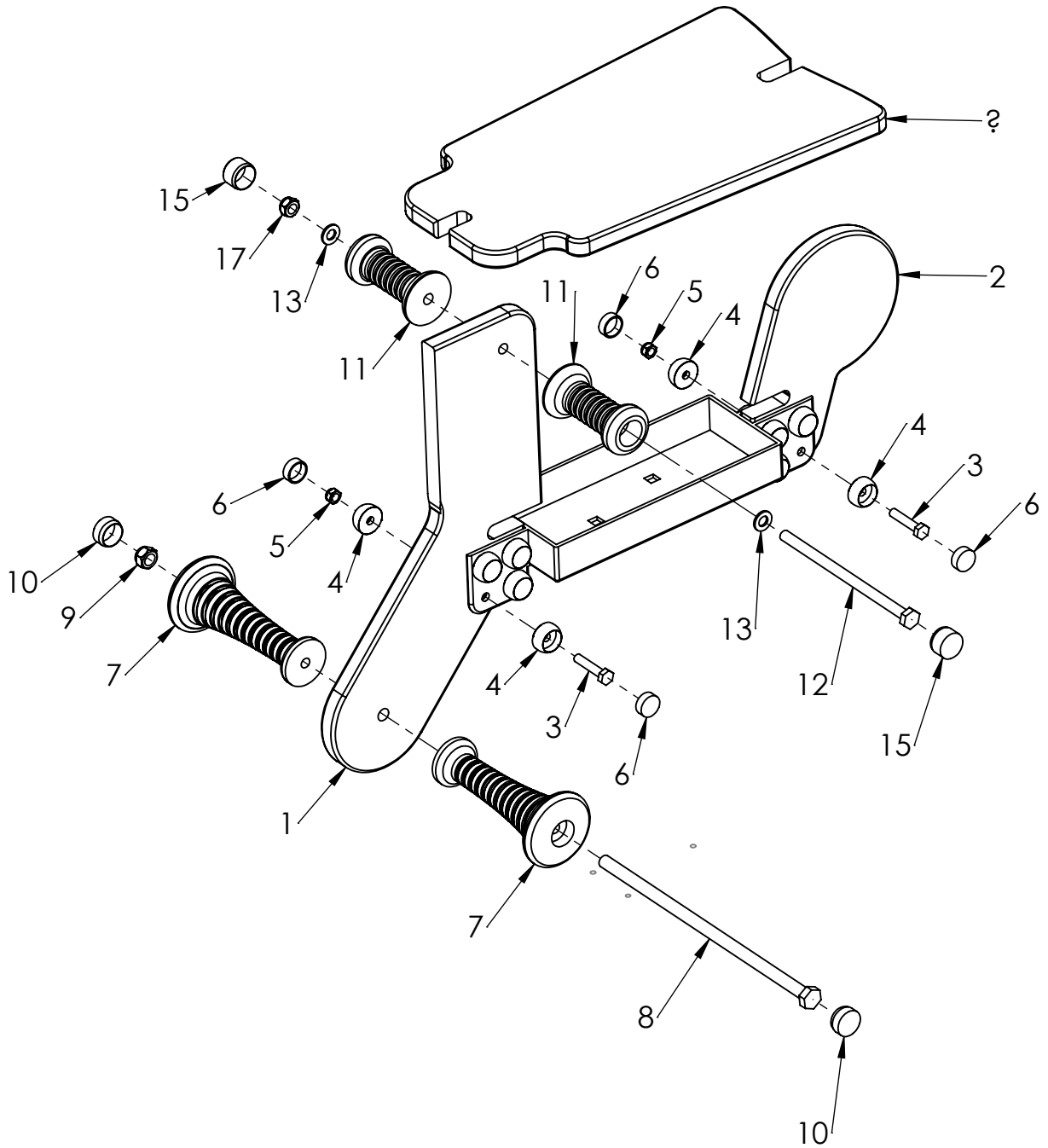

UNLESS OTHERWISE SPECIFIED:
 DIMENSIONS ARE IN MILLIMETERS
 WEIGHT ARE IN KILOGRAMM

PART NUMBER / DWG NO.:

VLO50

	NAME	SIGNATURE	DATE	REVISION
DRAWN	E.Reispere		18.03.2022	
APPV'D				

DESCRIPTION:

Spring swing LION

MATERIAL:

metal, plastic

A4

WEIGHT:

SCALE: 1:10

SHEET 9 OF 11



Tiptiptap ^{OO}

	1	2	3	4
	ITEM NO.	PART NUMBER	DESCRIPTION	
A	1	VLO50 support frame	HDPE plastic	
	2	tail for spring swing	plastic	
	3	bolt DIN933 M8x40	stainless steel	
	4	nut cover M8	PE plastic	
B	5	nut M8 DIN985	galvanized steel	
	6	nut cover cap M8	PE plastic	
	7	leg support	PE plastic	
	8	bolt DIN933 M12x305	galvanized steel	
	9	nut M12 DIN985	galvanized steel	
	10	leg support cup	PE plastic	
C	11	handle	PE plastic	
	12	bolt DIN933 M10x185	galvanized steel	
	13	washer M10 DIN125	galvanized steel	
	14	central console	painted steel	
	15	handle cup	PE plastic	
	16	VLO50 seat	HDPE plastic	
	17	nut M10 DIN985	stainless steel	

D

E

F

UNLESS OTHERWISE SPECIFIED: DIMENSIONS ARE IN MILLIMETERS WEIGHT ARE IN KILOGRAMM				PART NUMBER / DWG NO.:		VLO50	
	NAME	SIGNATURE	DATE	REVISION	DESCRIPTION: Spring swing LION		
DRAWN	E.Reispere		18.03.2022				
APPV'D					MATERIAL:		A4
 Tiptiptap ^{OU}				WEIGHT:		SCALE: 1:10	SHEET 10 OF 11

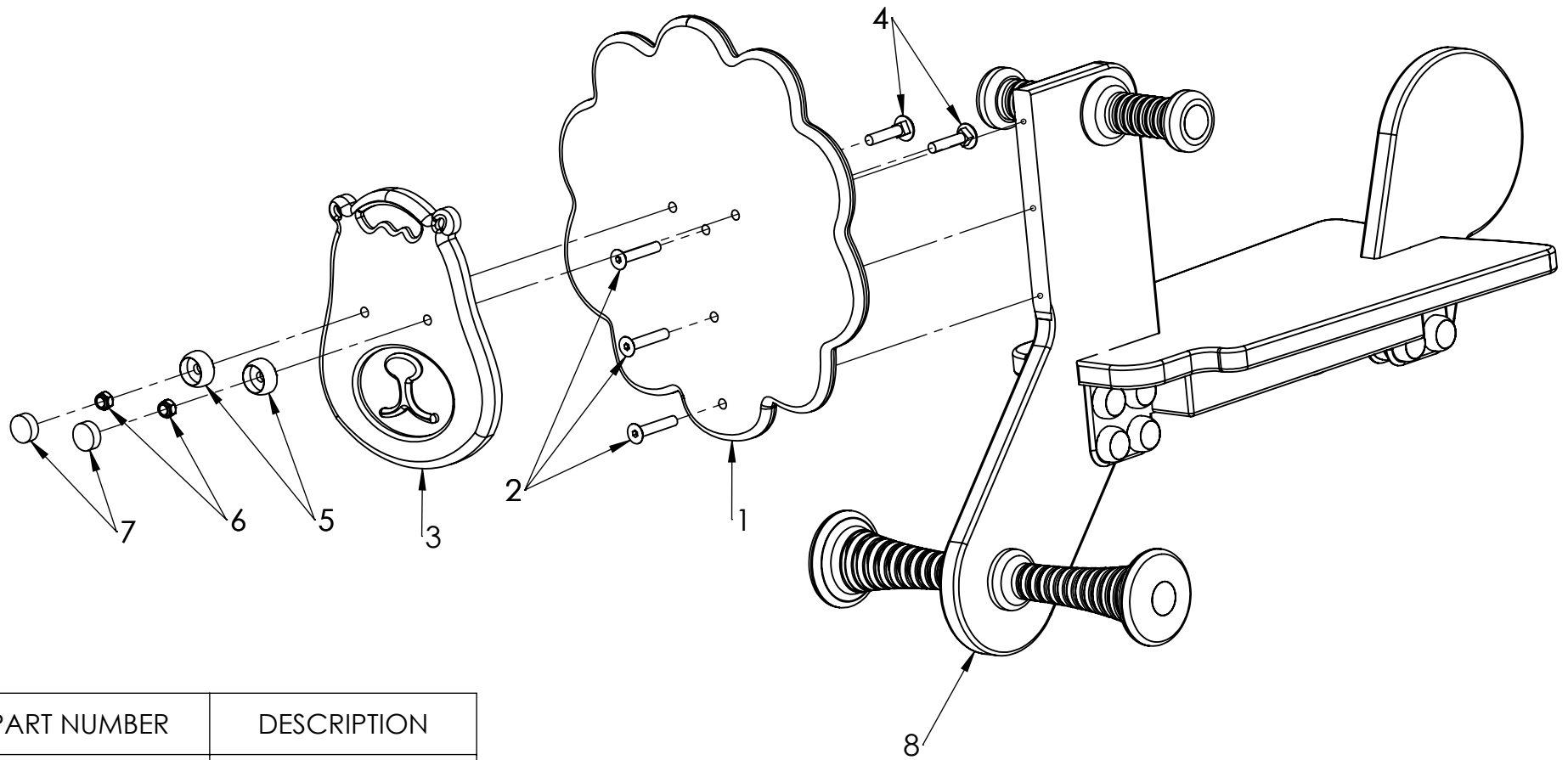

ITEM NO.	PART NUMBER	DESCRIPTION
1	VLO50 head	HDPE plastic
2	screw M8x40 DIN7991	galvanized steel
3	VLO50 face	HDPE plastic
4	bolt DIN603 M8x40	galvanized steel
5	nut cover M8	PE plastic
6	nut M8 DIN985	galvanized steel
7	nut cover cap M8	PE plastic
8	VLO50 support frame	HDPE plastic

UNLESS OTHERWISE SPECIFIED:
DIMENSIONS ARE IN MILLIMETERS
WEIGHT ARE IN KILOGRAMM

	NAME	SIGNATURE	DATE	REVISION
DRAWN	R.Fedotov		18.03.2022	
APPV'D				



Tiptap OÜ

PART NUMBER / DWG NO.:

VLO50

DESCRIPTION:

Spring swing LION

MATERIAL:

metal, plastic

A4

WEIGHT:

SCALE: 1:10

SHEET 11 OF 11