

A

B

C

D

E

F

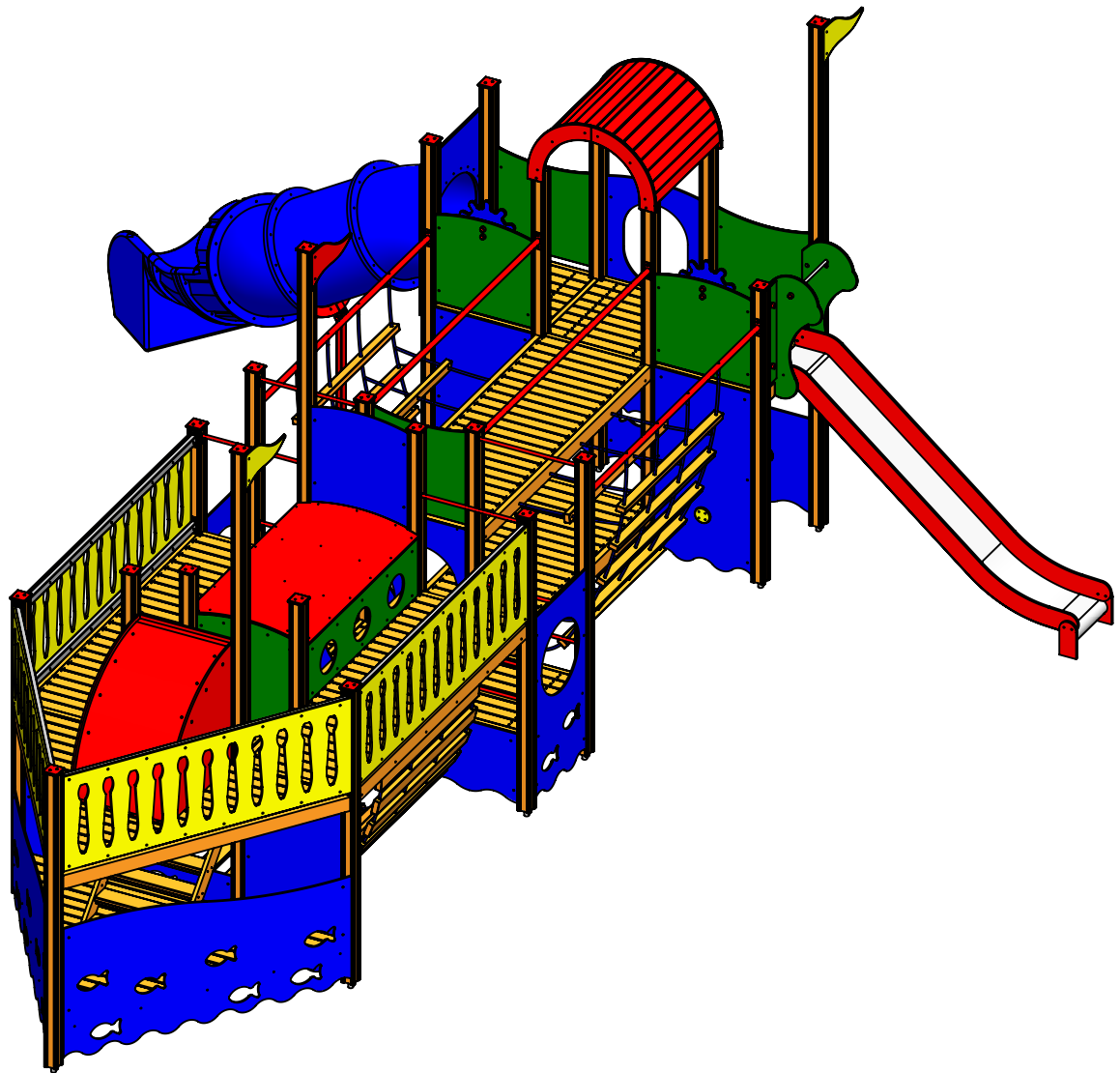

UNLESS OTHERWISE SPECIFIED:
 DIMENSIONS ARE IN MILLIMETERS
 WEIGHT ARE IN KILOGRAMM

PART NUMBER / DWG NO.:

MM118

	NAME	SIGNATURE	DATE	REVISION
DRAWN	M.Rebase		31.03.2022	
APPV'D				

DESCRIPTION:

Playship NOA



Tiptiptap OÜ

MATERIAL:

A4

WEIGHT:

SCALE: 1:50

SHEET 1 OF 40

A

B

C

D

E

F

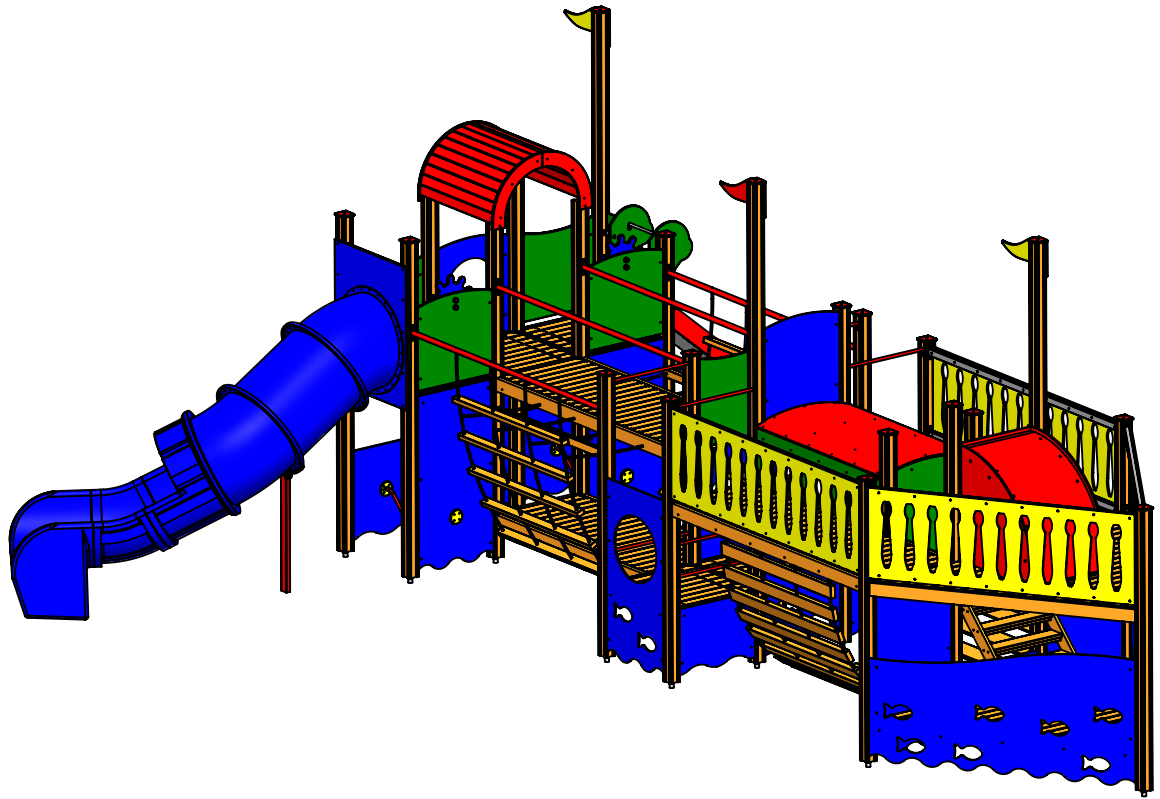
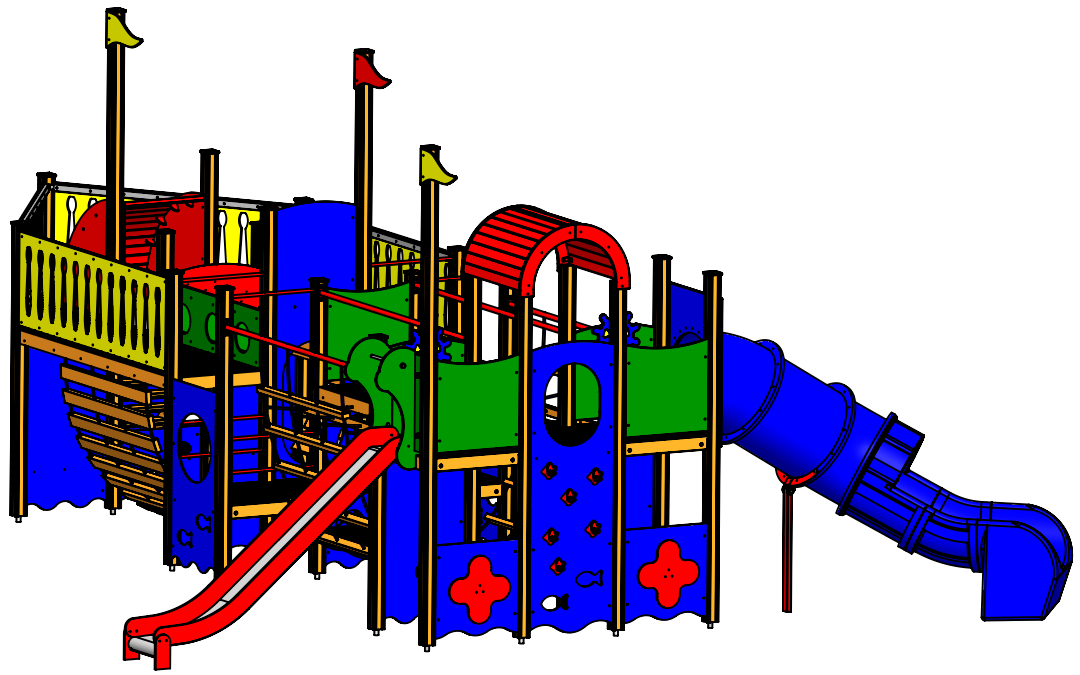

UNLESS OTHERWISE SPECIFIED:
 DIMENSIONS ARE IN MILLIMETERS
 WEIGHT ARE IN KILOGRAMM

	NAME	SIGNATURE	DATE	REVISION
DRAWN	M.Rebase		31.03.2022	
APPV'D				

PART NUMBER / DWG NO.:
MM118

DESCRIPTION:
Playship NOA



Tiptiptap OÜ

MATERIAL:
 A4

WEIGHT: SCALE: 1:60 SHEET 2 OF 40

foundation

A

B

C

D

E

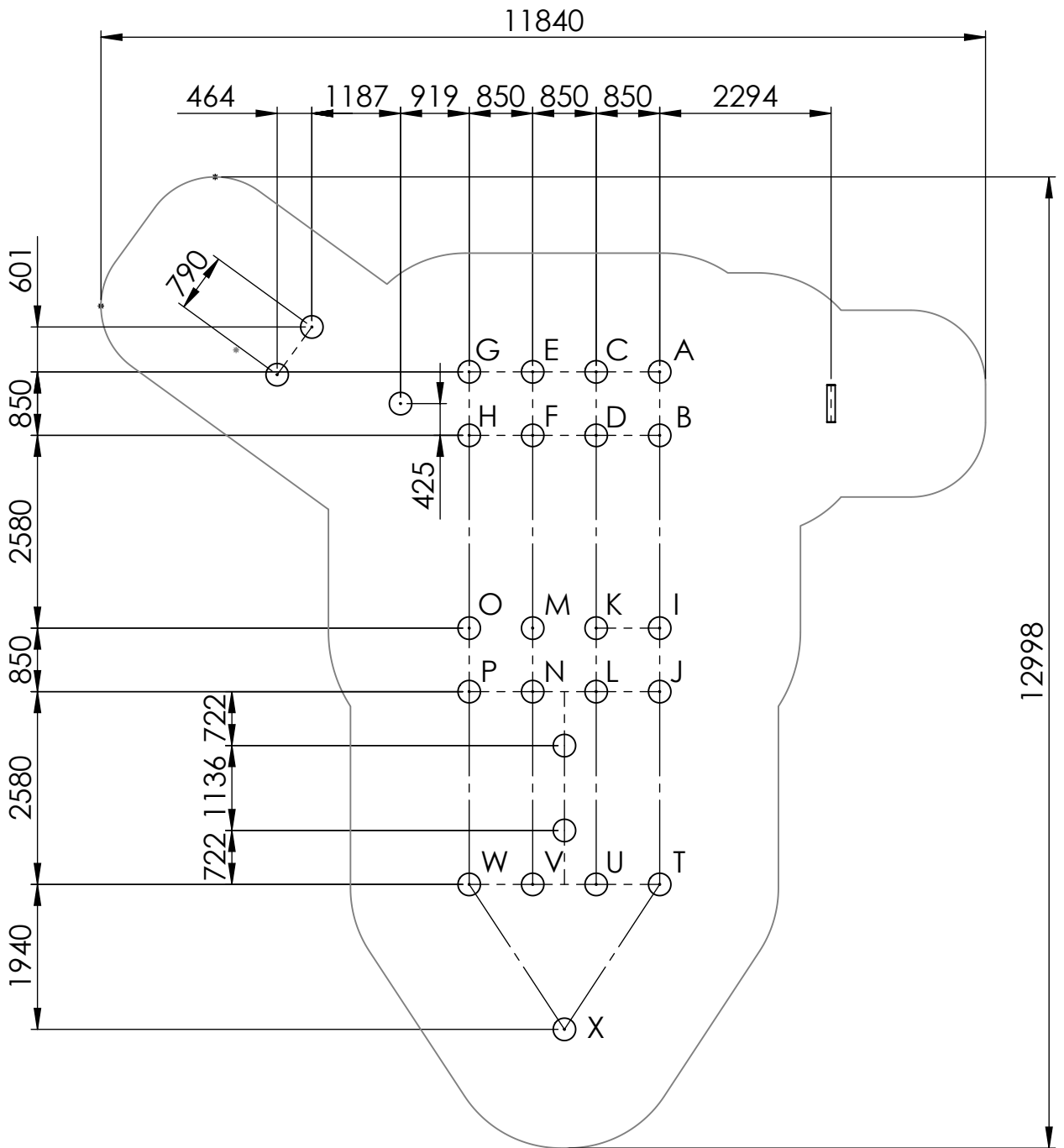

depth of foundation 600mm

UNLESS OTHERWISE SPECIFIED:
DIMENSIONS ARE IN MILLIMETERS
WEIGHT ARE IN KILOGRAMM

PART NUMBER / DWG NO.:

MM118

	NAME	SIGNATURE	DATE	REVISION
DRAWN	M.Rebase		31.03.2022	
APPV'D				

DESCRIPTION:

Playship NOA

F



Tiptiptap OÜ

MATERIAL:

A4

WEIGHT:

SCALE: 1:85

SHEET 4 OF 40

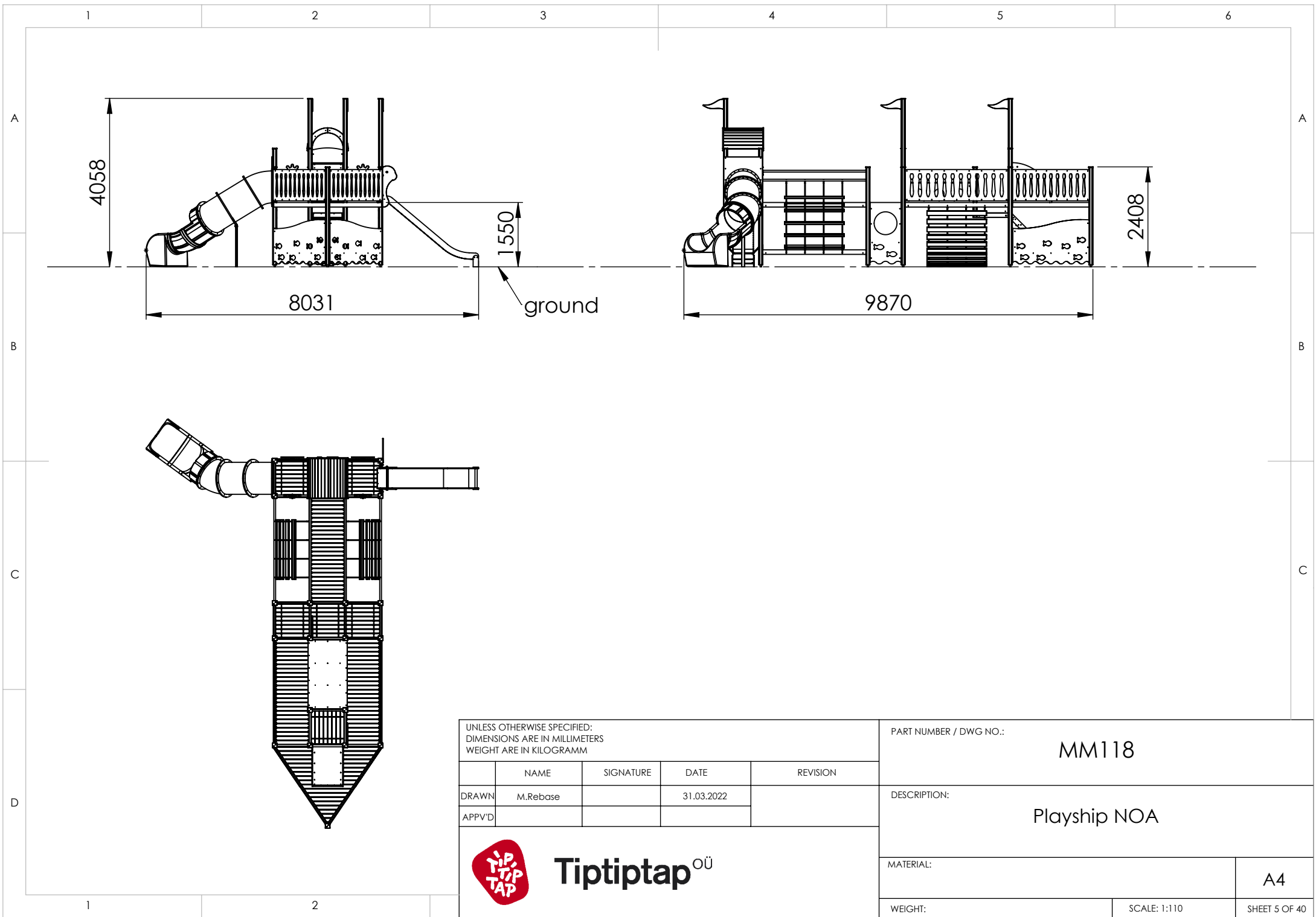

UNLESS OTHERWISE SPECIFIED:
 DIMENSIONS ARE IN MILLIMETERS
 WEIGHT ARE IN KILOGRAMM

	NAME	SIGNATURE	DATE	REVISION
DRAWN	M.Rebase		31.03.2022	
APPV'D				

PART NUMBER / DWG NO.:
MM118

DESCRIPTION:
Playship NOA



MATERIAL:		A4
WEIGHT:	SCALE: 1:110	SHEET 5 OF 40

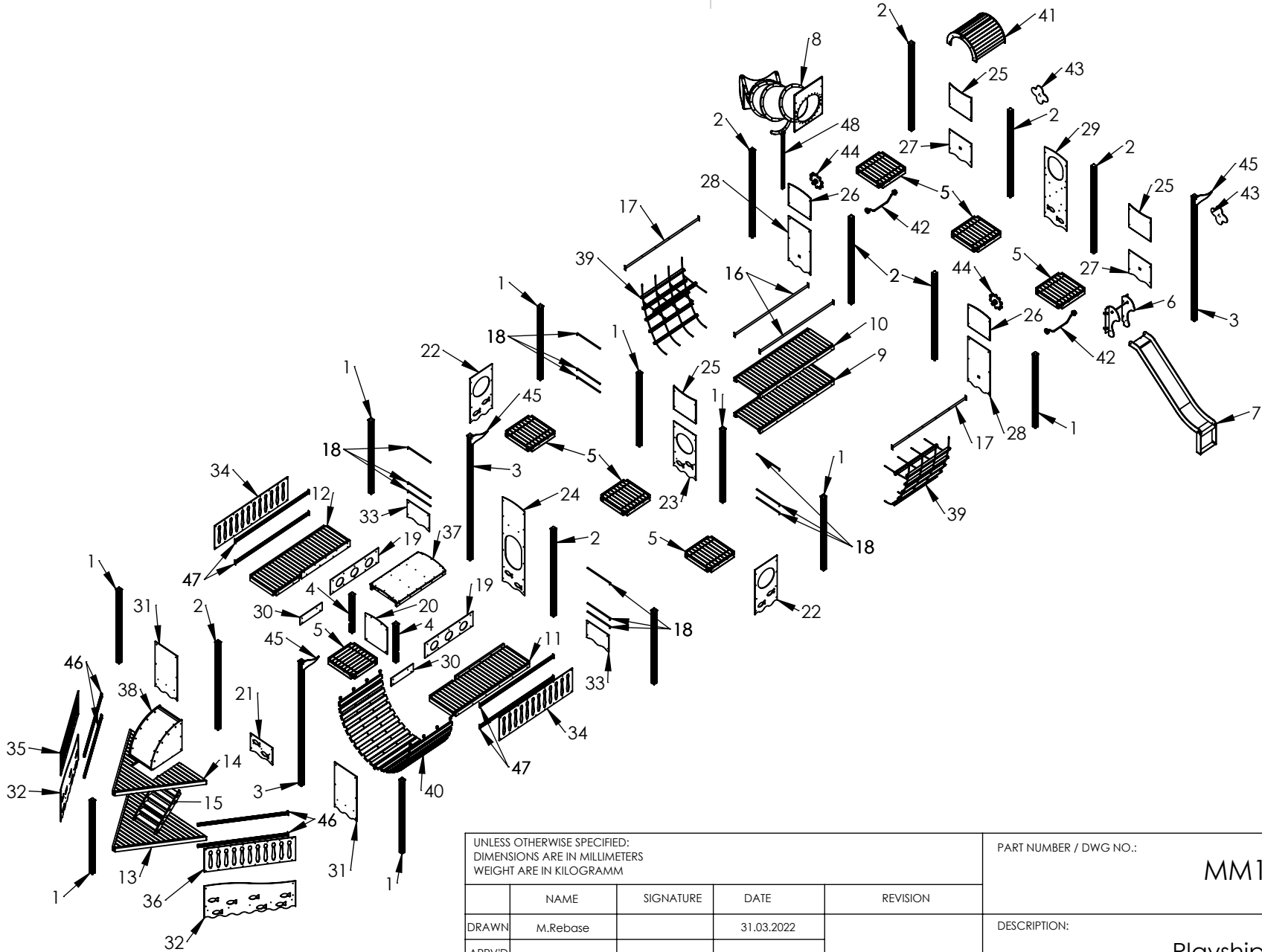

UNLESS OTHERWISE SPECIFIED:
DIMENSIONS ARE IN MILLIMETERS
WEIGHT ARE IN KILOGRAMM

	NAME	SIGNATURE	DATE	REVISION
DRAWN	M.Rebase		31.03.2022	
APPV'D				

PART NUMBER / DWG NO.:
MM118

DESCRIPTION:
Playship NOA



MATERIAL:	A4
WEIGHT:	SCALE: 1:135 SHEET 6 OF 40

ITEM NO.	PART NUMBER	QTY.
A 1	post 98x98x2350	10
2	post 98x98x2800	8
3	post 98x98x4000	3
4	post 98x98x1210	2
5	platform	7
B 6	slide guard block	1
7	slide h.1550	1
8	tunnel slide	1
9	platvorm 1 (L-2500)	1
10	platvorm 2 (L-2500)	1
11	platvorm 3 (L-2500)	1
12	platvorm 4 (L-2500)	1
C 13	lower triangle platform	1
14	upper triangle platform	1
15	stairs	1
16	tube \varnothing 40x2500	2
17	tube \varnothing 40x2500, 4 holes	2
18	guardrail \varnothing 25x770	12
19	panel 1630x470	2
D 20	panel 750x658	1
21	paneel 550x750	1
22	panel 750x1450_A	2
23	panel 750x1450_B	1
24	panel 750x2765	1
25	panel 750x750, lower hole 100mm	3
26	upward curved panel 750x750, lower hole 100mm	2
27	panel 750x750	2
28	panel 750x1480	2
E		

UNLESS OTHERWISE SPECIFIED: DIMENSIONS ARE IN MILLIMETERS WEIGHT ARE IN KILOGRAMM				
	NAME	SIGNATURE	DATE	REVISION
DRAWN	M.Rebase		31.03.2022	
APPV'D				

PART NUMBER / DWG NO.:		MM118	
DESCRIPTION:		Playship NOA	
MATERIAL:		A4	
WEIGHT:		SCALE: 1:135	SHEET 7 OF 40



ITEM NO.	PART NUMBER	QTY.
29	panel 750x2250 with climbing grips	1
30	panel 250x750	2
31	panel 750x1400	2
32	panel 1060x2238	2
33	panel 550x750	2
34	side panel 2480x755	2
35	side panel 2232x755_left	1
36	side panel 2232x755_right	1
37	ships hold	1
38	roof for stairs	1
39	climbing net_A	2
40	climbing net_B	1
41	roof	1
42	crank handle	2
43	propeller	2
44	captain wheel	2
45	flag	3
46	beam 40x60x2220	4
47	beam 40x60x2500	4
48	tunnel slide support	1

D	
E	

UNLESS OTHERWISE SPECIFIED: DIMENSIONS ARE IN MILLIMETERS WEIGHT ARE IN KILOGRAMM				PART NUMBER / DWG NO.: MM118	
	NAME	SIGNATURE	DATE	REVISION	
DRAWN	M.Rebase		31.03.2022	DESCRIPTION: Playship NOA	
APPV'D				MATERIAL:	
 Tiptiptap OÜ				A4	
WEIGHT:				SCALE: 1:135	SHEET 8 OF 40

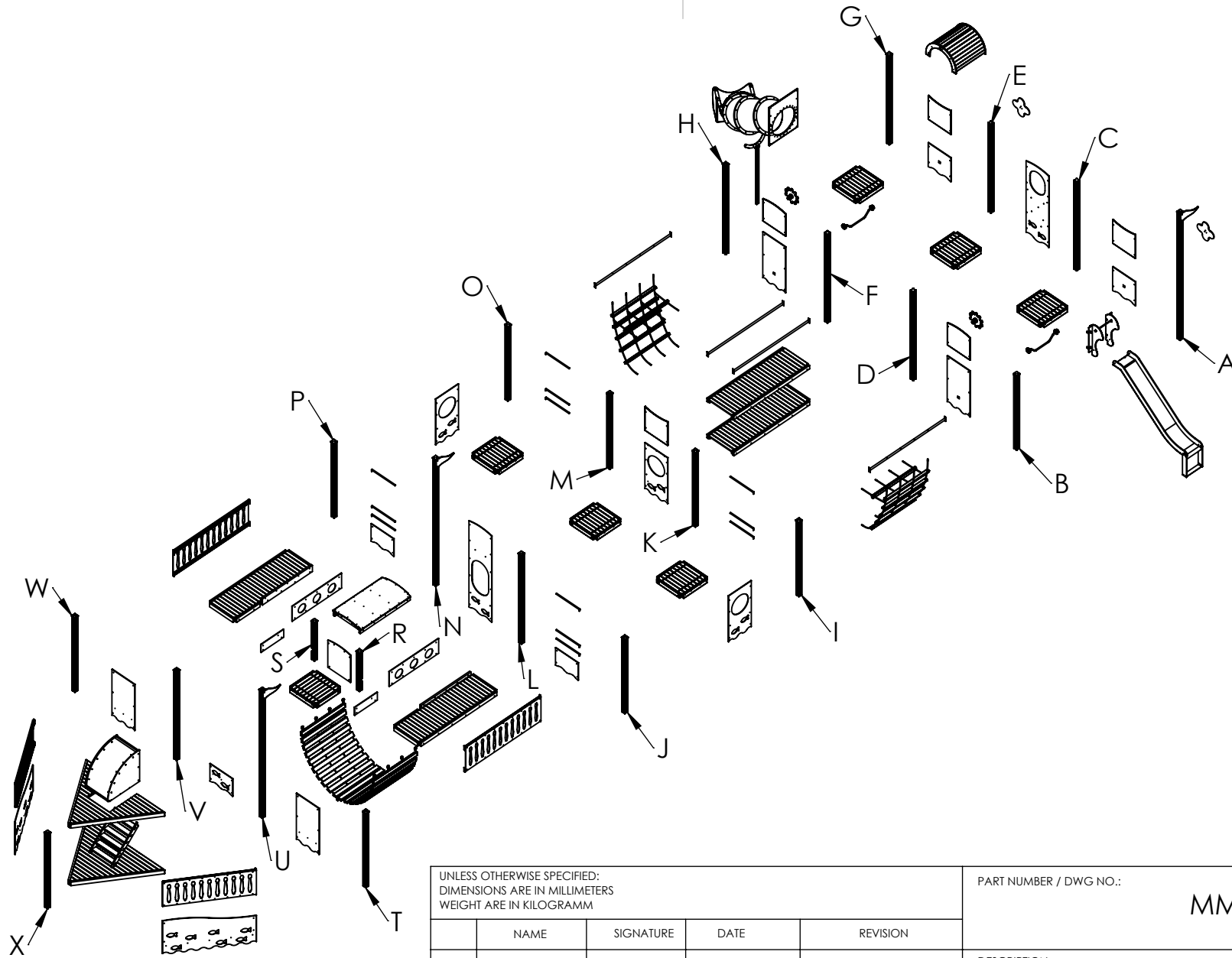

UNLESS OTHERWISE SPECIFIED:
 DIMENSIONS ARE IN MILLIMETERS
 WEIGHT ARE IN KILOGRAMM

	NAME	SIGNATURE	DATE	REVISION
DRAWN	M.Rebase		31.03.2022	
APPV'D				

PART NUMBER / DWG NO.:
MM118

DESCRIPTION:
Playship NOA





MATERIAL:	A4
WEIGHT:	SCALE: 1:135
	SHEET 9 OF 40

Before concreting:

1. Install all posts, platforms and metal beams.
2. Install all panels, guardrails, slides and other parts.

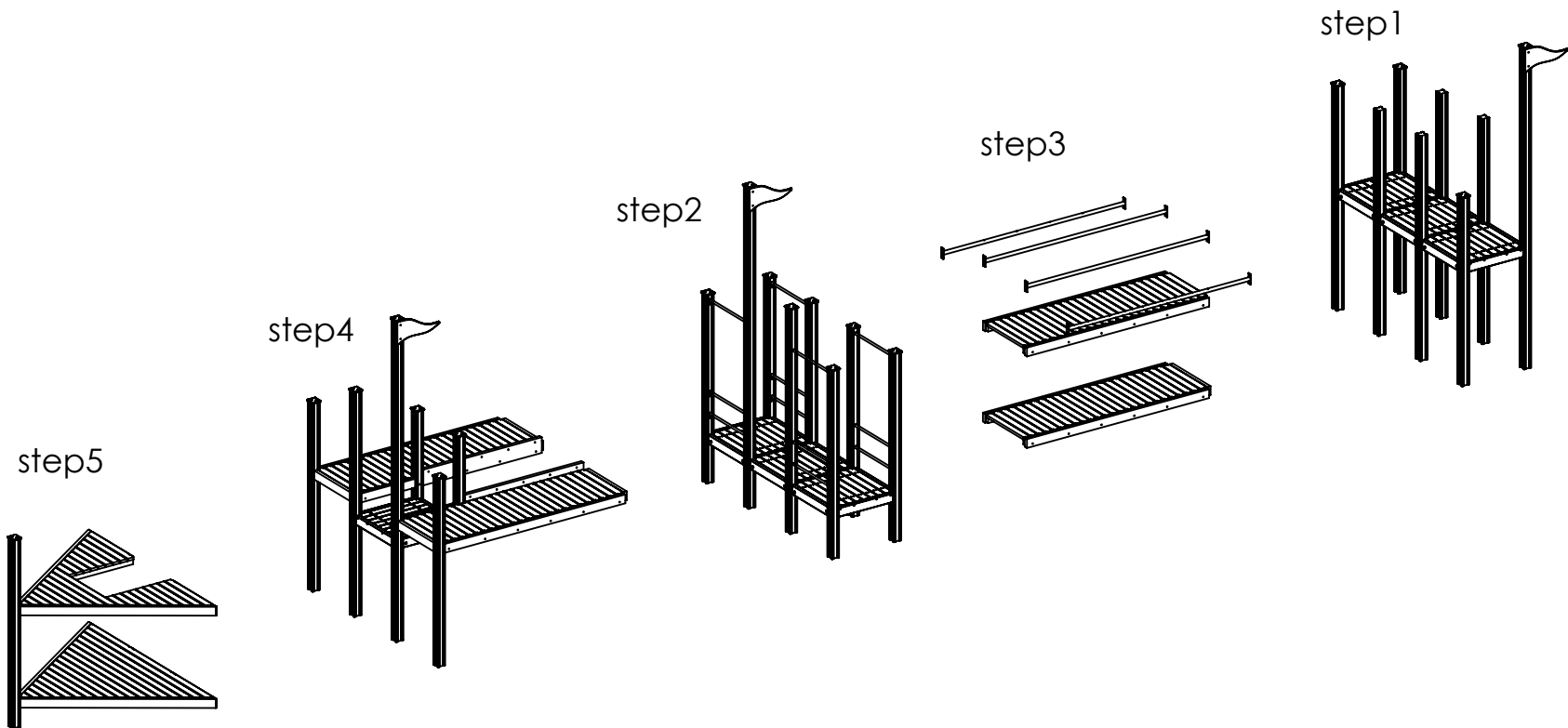
In some situations You may temporarily need to remove plastic cap from the post.



UNLESS OTHERWISE SPECIFIED: DIMENSIONS ARE IN MILLIMETERS WEIGHT ARE IN KILOGRAMM					PART NUMBER / DWG NO.:	
					MM118	
	NAME	SIGNATURE	DATE	REVISION	DESCRIPTION:	
DRAWN	M.Rebase		31.03.2022		Playship NOA	
APPV'D					MATERIAL:	
 Tiptiptap OÜ					A4	
					WEIGHT:	

A

B

C

D

E

F

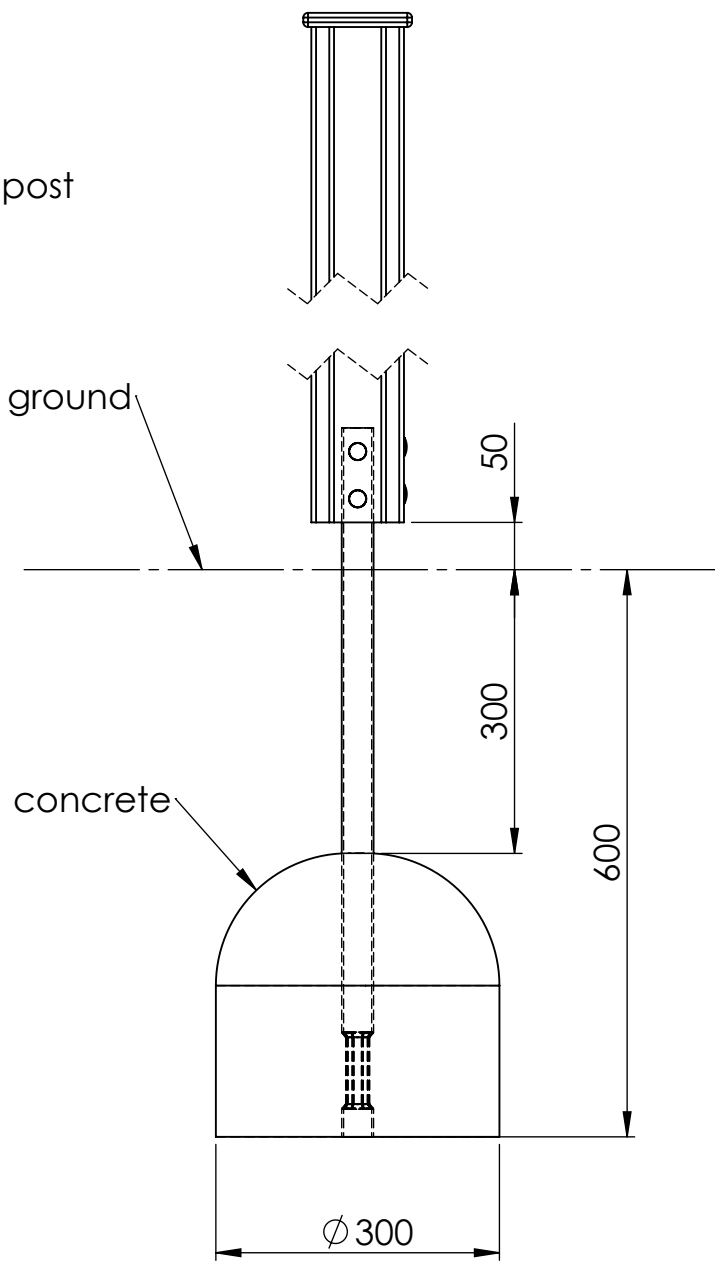
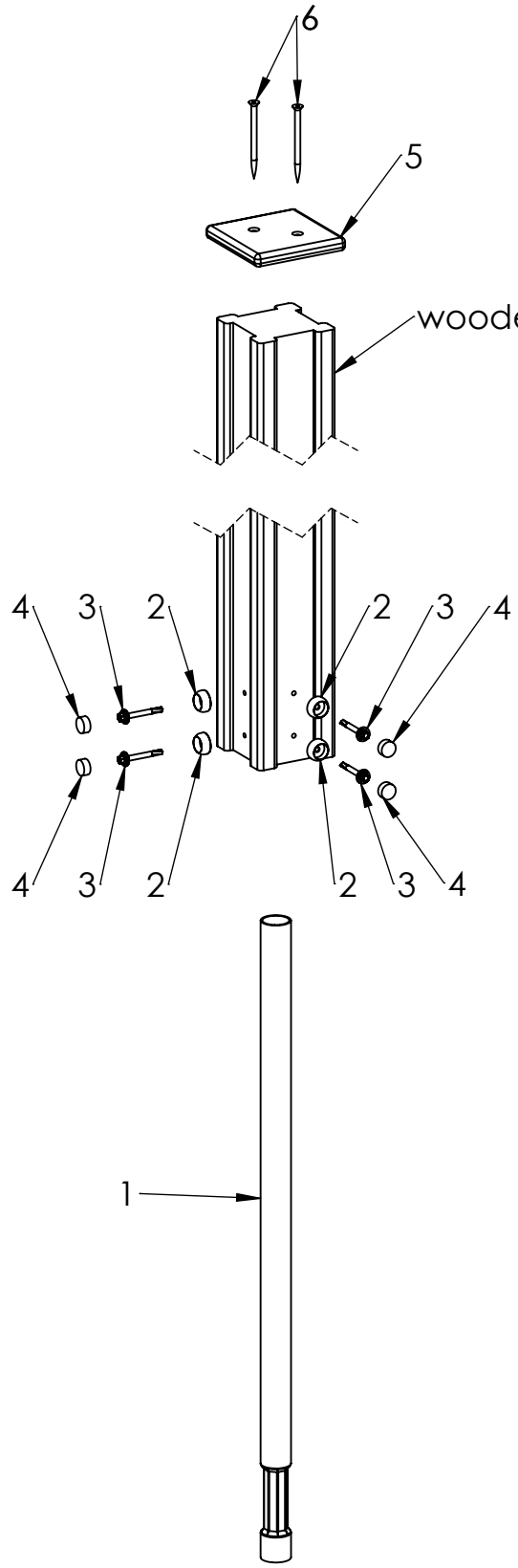

ITEM NO.	PART NUMBER
1	metal ground fixing L_750
2	nut cover M6
3	screw 5,5x50 DIN7504K
4	nut cover cap M6
5	plastic cap 115x115
6	wood screw 6 x 90

UNLESS OTHERWISE SPECIFIED: DIMENSIONS ARE IN MILLIMETERS WEIGHT ARE IN KILOGRAMM				
	NAME	SIGNATURE	DATE	REVISION
DRAWN	M.Rebase		31.03.2022	
APPV'D				

PART NUMBER / DWG NO.:
MM118

DESCRIPTION:
**Playship NOA
connecting metal ground fixing to post**



MATERIAL:	A4
WEIGHT:	SCALE: 1:8
	SHEET 11 OF 40

A

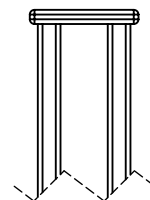
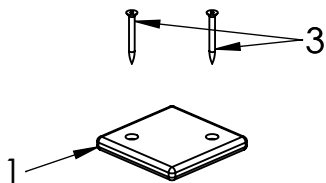

B

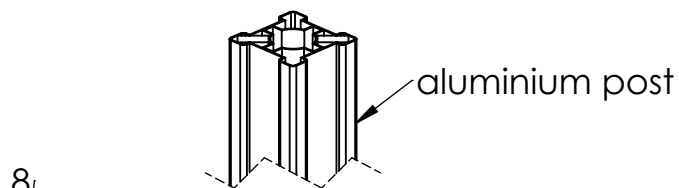

ground

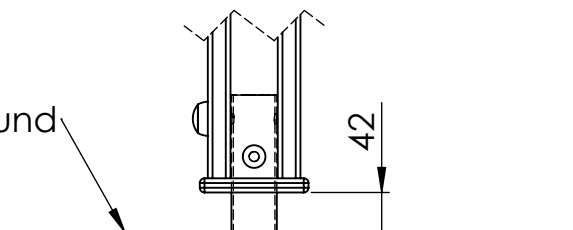

C

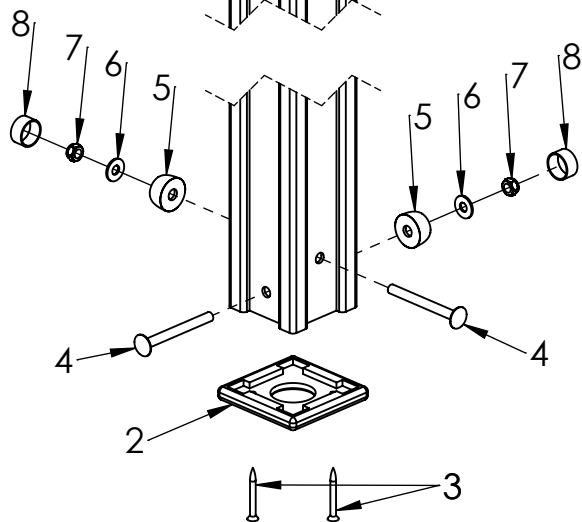

concrete

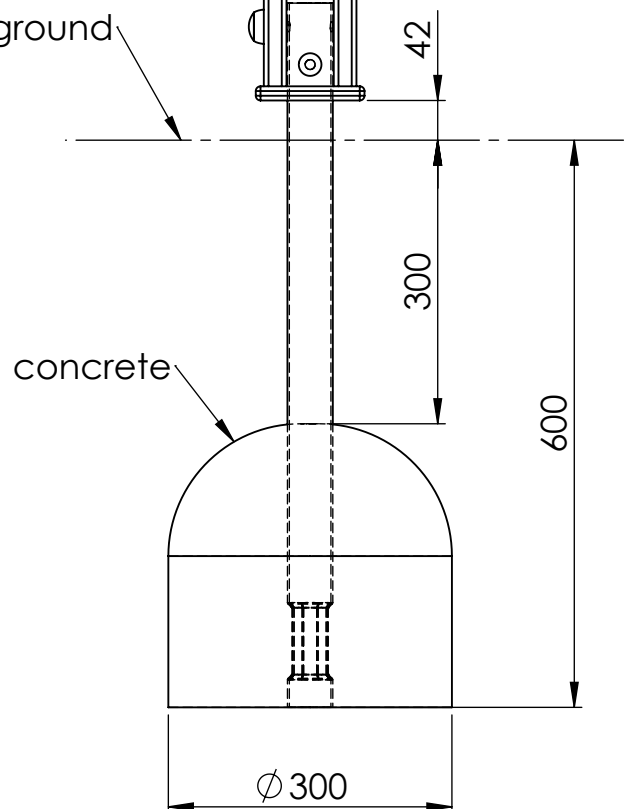

D

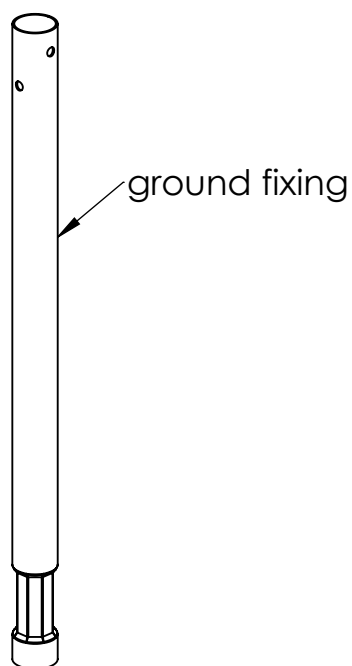

E

ITEM NO.	PART NUMBER
1	plastic cap 115x115
2	plastic cap 115x115 with hole
3	wood screw 6 x 60
4	bolt M10x100 DIN603
5	nut cover M12
6	washer M10 DIN9054
7	nut M10 DIN985
8	nut cover cap M12

UNLESS OTHERWISE SPECIFIED:
DIMENSIONS ARE IN MILLIMETERS
WEIGHT ARE IN KILOGRAMM

PART NUMBER / DWG NO.:

MM118

	NAME	SIGNATURE	DATE	REVISION
DRAWN	M.Rebase		31.03.2022	
APPV'D				

DESCRIPTION:

Playship NOA
connecting metal ground fixing to post

F



Tiptaptap OÜ

Tiptaptap OÜ
Veetorni 9,
Jüri alevik, Rae vald,
75301 Harjumaa

MATERIAL:

A4

WEIGHT:

SCALE: 1:8

SHEET 12 OF 40

A

B

C

D

E

F

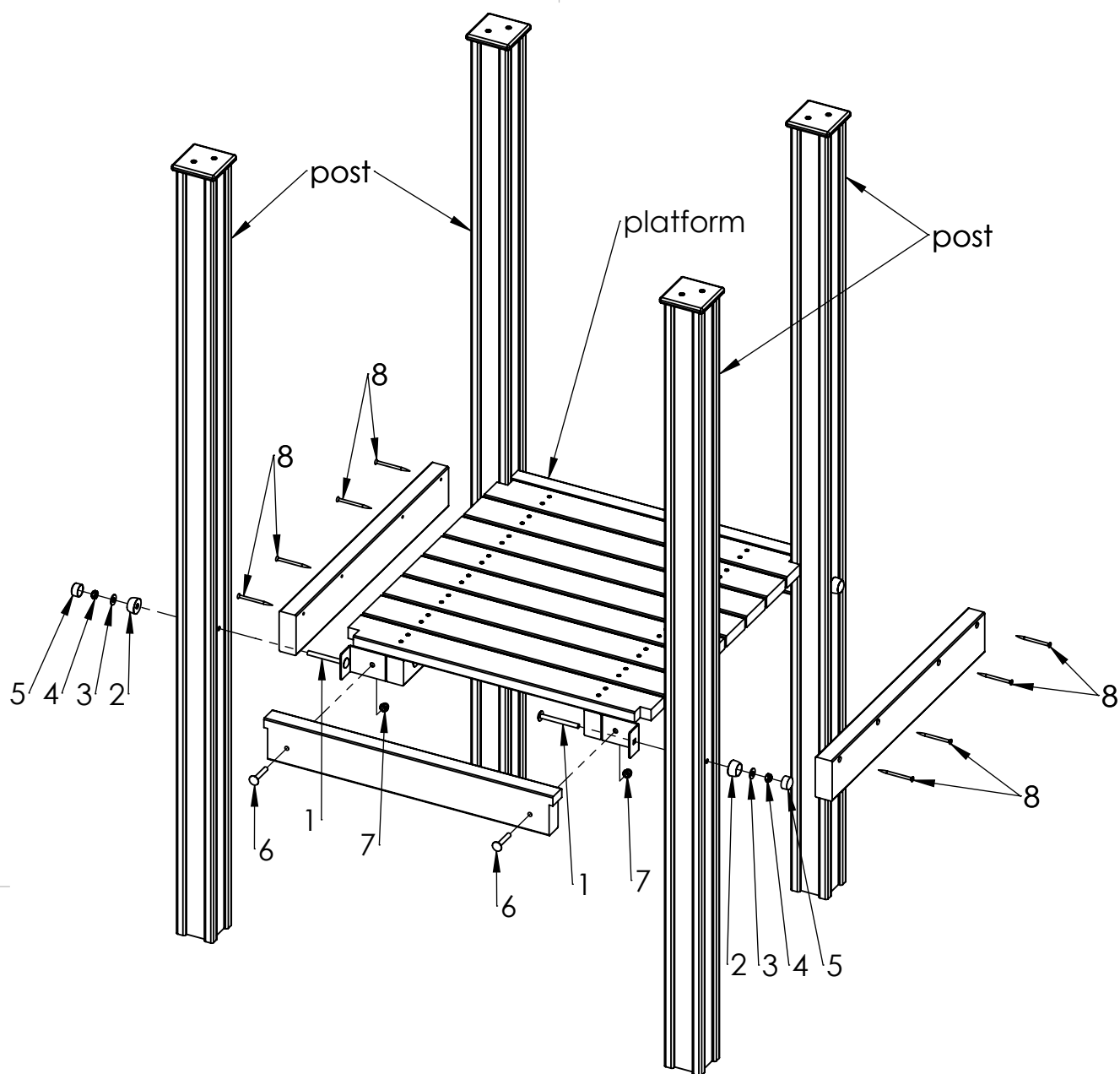

ITEM NO.	PART NUMBER
1	bolt M10x100 DIN603
2	nut cover M12
3	washer M10 DIN9054
4	nut M10 DIN985
5	nut cover cap M12
6	bolt M10x60 DIN603
7	domed cap nut M10 DIN986
8	wood screw 6 x 90

UNLESS OTHERWISE SPECIFIED:
DIMENSIONS ARE IN MILLIMETERS
WEIGHT ARE IN KILOGRAMM

PART NUMBER / DWG NO.:

MM118

	NAME	SIGNATURE	DATE	REVISION
DRAWN	M.Rebase		31.03.2022	
APPV'D				

DESCRIPTION:

Playship NOA
connecting platform to post

MATERIAL:

A4

WEIGHT:

SCALE: 1:15

SHEET 13 OF 40



Tiptiptap OÜ

A

B

C

D

E

F

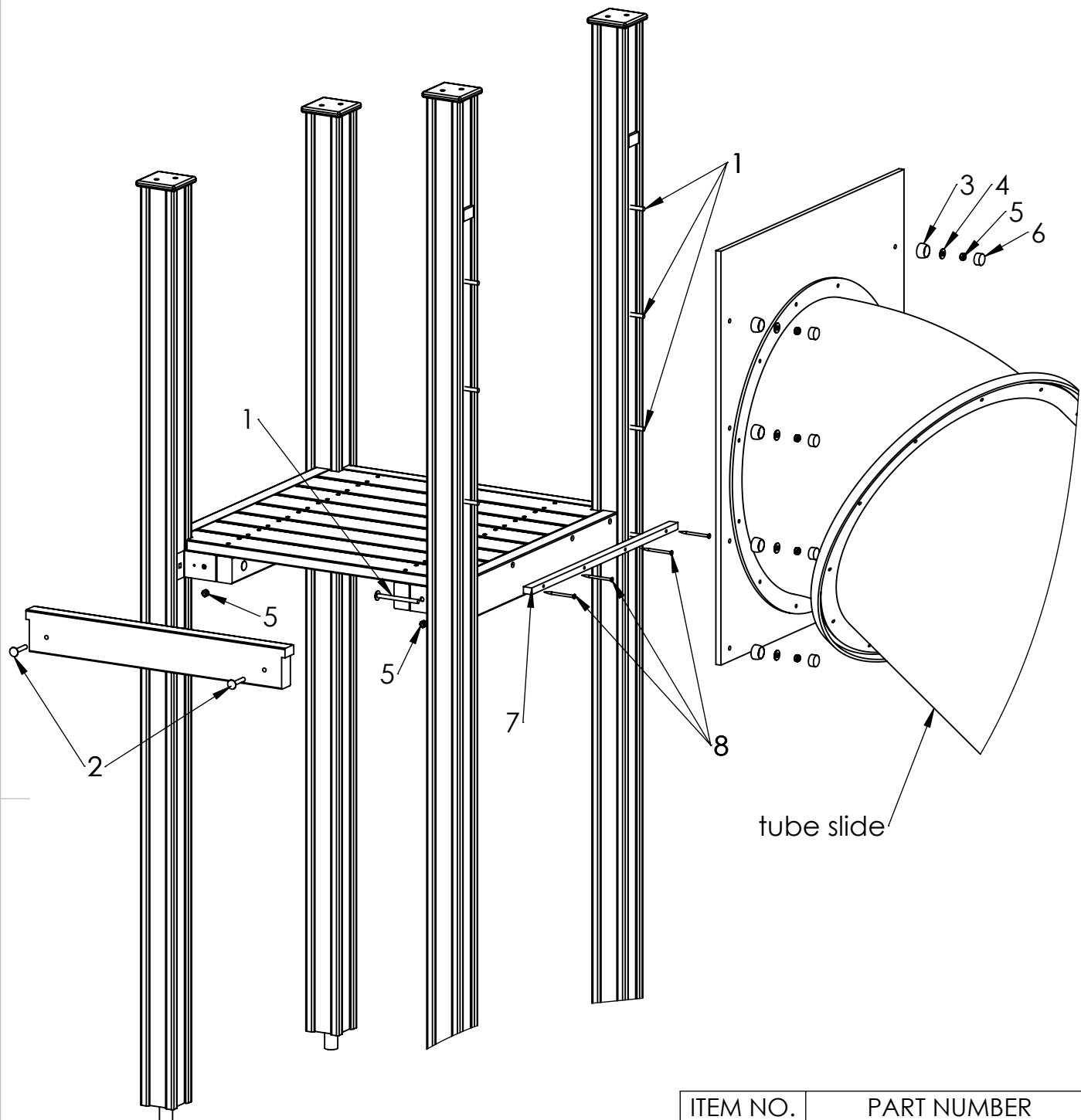

ITEM NO.	PART NUMBER
1	bolt DIN603 M10x120
2	bolt DIN603 M10x60
3	nut cover M12
4	Washer M10 DIN7349
5	nut DIN985 M10
6	nut cover cap M12
7	lath 750x25x18
8	Woodscrew 6 x 90

UNLESS OTHERWISE SPECIFIED: DIMENSIONS ARE IN MILLIMETERS WEIGHT ARE IN KILOGRAMM				
	NAME	SIGNATURE	DATE	REVISION
DRAWN	M.Rebase		31.03.2022	
APPV'D				

PART NUMBER / DWG NO.:	MM118
DESCRIPTION:	Playship NOA



MATERIAL:	A4
WEIGHT:	SCALE: 1:20
	SHEET 14 OF 40

1

2

3

4

5

6

A

B

C

D

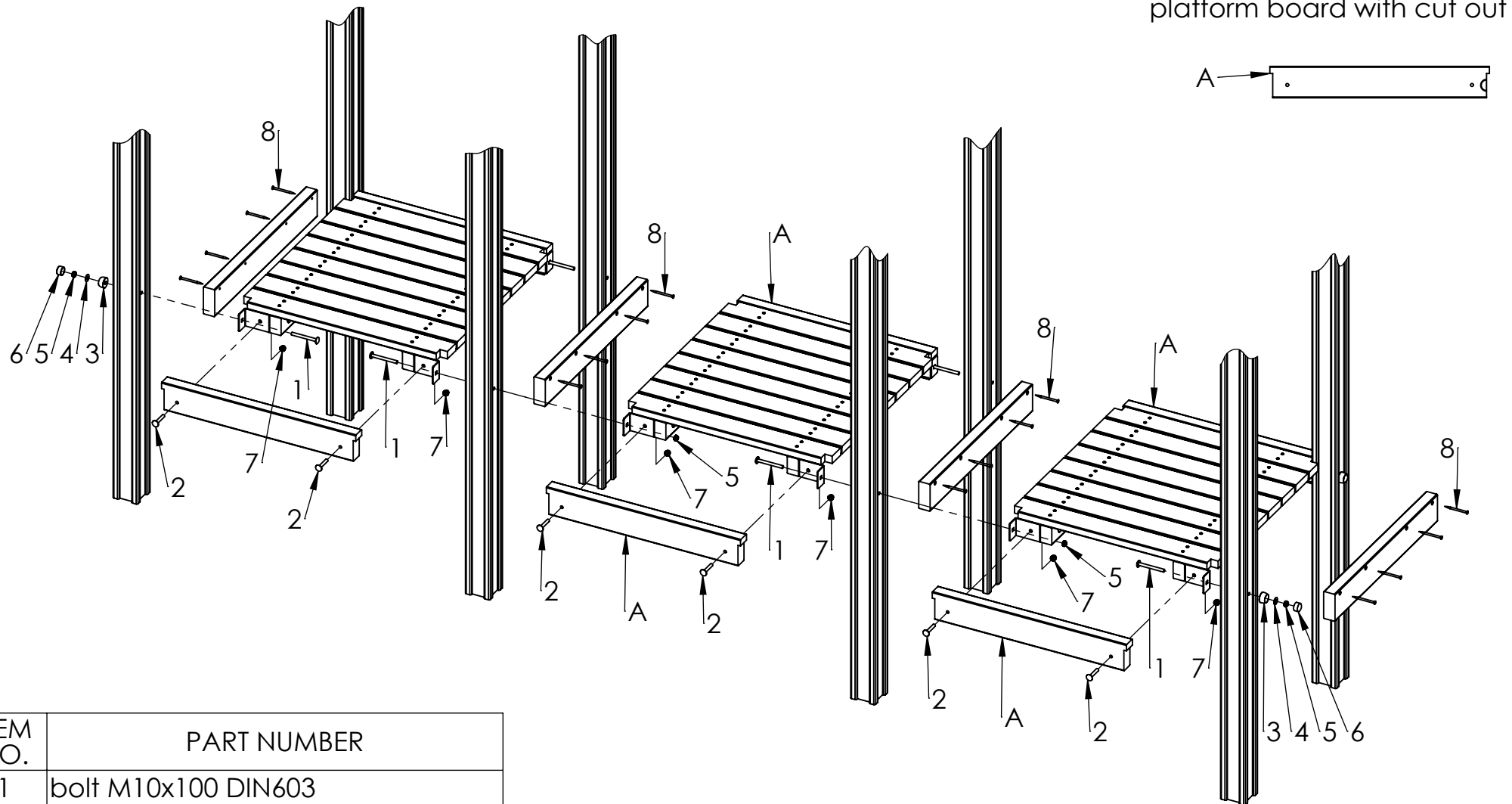

ITEM NO.	PART NUMBER
1	bolt M10x100 DIN603
2	bolt M10x60 DIN603
3	nut cover M12
4	washer M10 DIN9054
5	nut M10 DIN985
6	nut cover cap M12
7	domed cap nut M10 DIN986
8	wood screw 6 x 90

UNLESS OTHERWISE SPECIFIED:
DIMENSIONS ARE IN MILLIMETERS
WEIGHT ARE IN KILOGRAMM

	NAME	SIGNATURE	DATE	REVISION
DRAWN	M.Rebase		31.03.2022	
APPV'D				



Tiptap OÜ

PART NUMBER / DWG NO.:

MM118

DESCRIPTION:

Playship NOA
connecting three platforms

MATERIAL:

A4

WEIGHT:

SCALE: 1:20

SHEET 15 OF 40

1 2 3 4 5 6

A

B

C

D

A

B

C

D

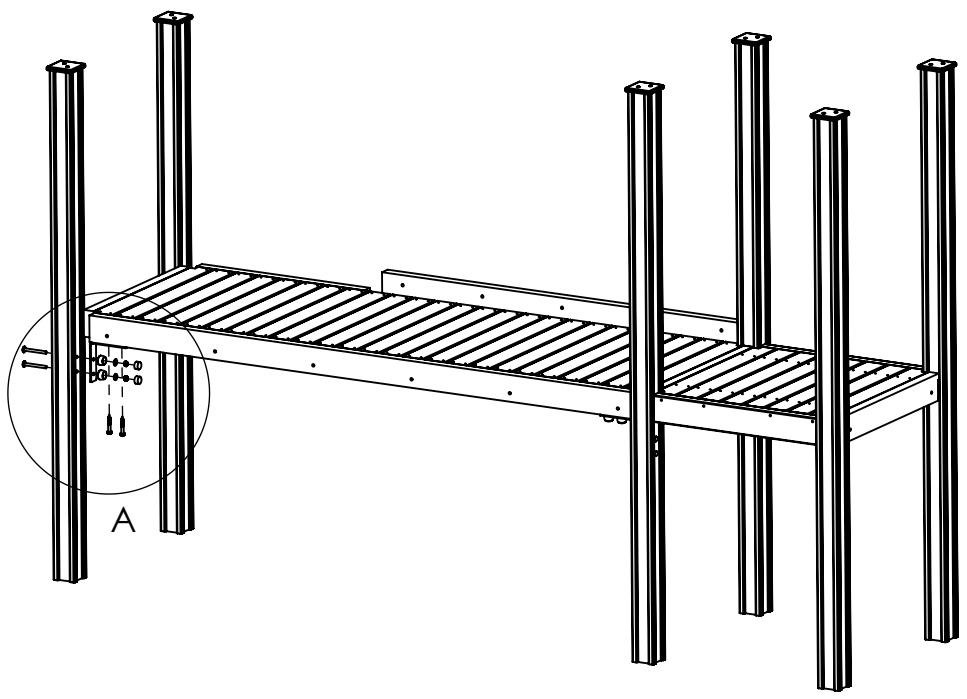

ITEM NO.	PART NUMBER
1	corner 165x165x45
2	bolt M10x100 DIN603
3	nut cover M12
4	washer M10 DIN9054
5	nut M10 DIN985
6	nut cover cap M12
7	wide head wood screw 10x60

DETAIL A
SCALE 1 : 10

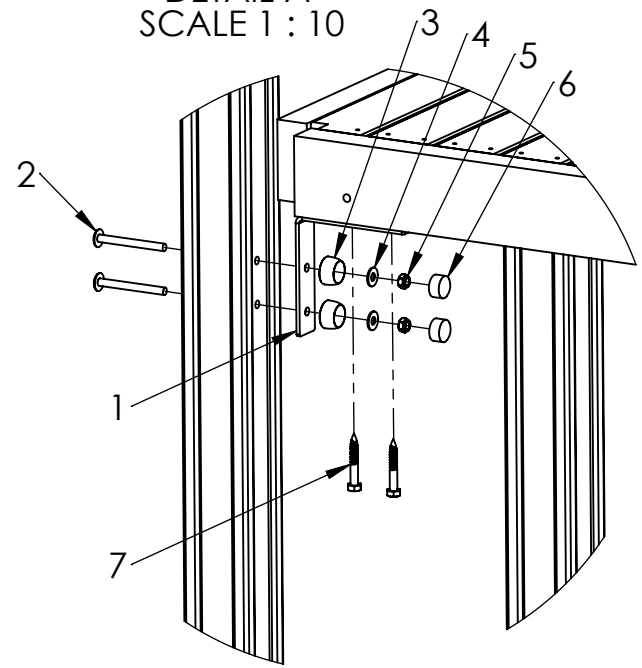

UNLESS OTHERWISE SPECIFIED:
DIMENSIONS ARE IN MILLIMETERS
WEIGHT ARE IN KILOGRAMM

	NAME	SIGNATURE	DATE	REVISION
DRAWN	M.Rebase		31.03.2022	
APPV'D				

PART NUMBER / DWG NO.:
MM118

DESCRIPTION:
**Playship NOA
connecting platform to post**



MATERIAL:	A4
WEIGHT:	SCALE: 1:30
	SHEET 16 OF 40

1 2

A

B

C

D

E

F

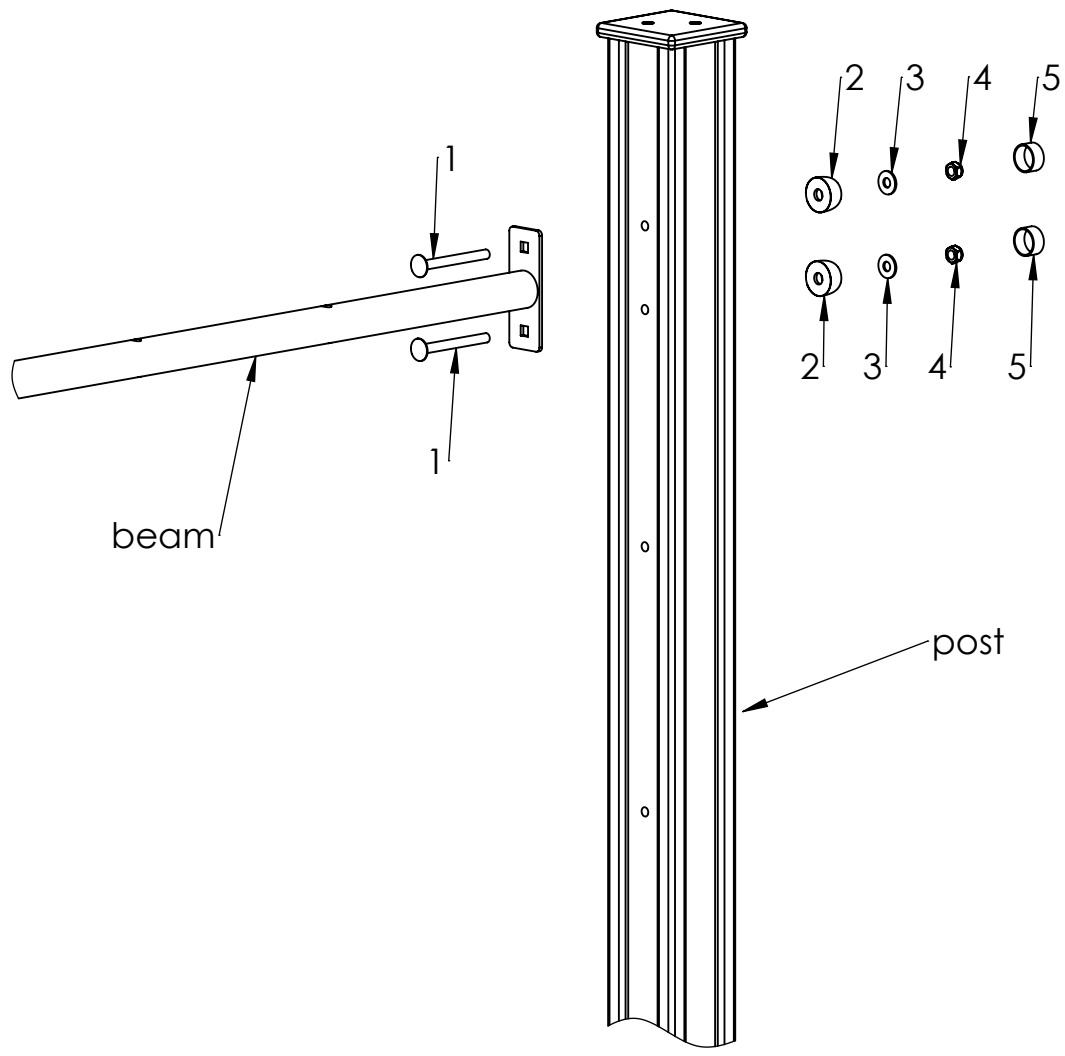

ITEM NO.	PART NUMBER
1	bolt M10x100 DIN603
2	nut cover M12
3	washer M10 DIN9054
4	nut M10 DIN985
5	nut cover cap M12

UNLESS OTHERWISE SPECIFIED: DIMENSIONS ARE IN MILLIMETERS WEIGHT ARE IN KILOGRAMM				
	NAME	SIGNATURE	DATE	REVISION
DRAWN	M.Rebase		31.03.2022	
APPV'D				

PART NUMBER / DWG NO.:		MM118	
DESCRIPTION:			
Playship NOA connecting beam to post			
MATERIAL:		A4	
WEIGHT:		SCALE: 1:8	
		SHEET 17 OF 40	



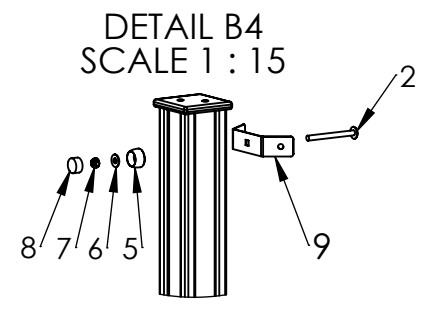
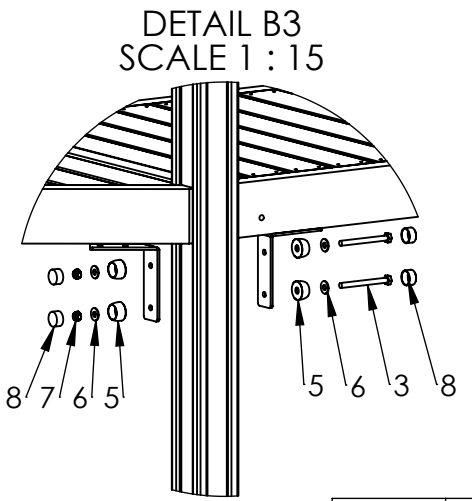
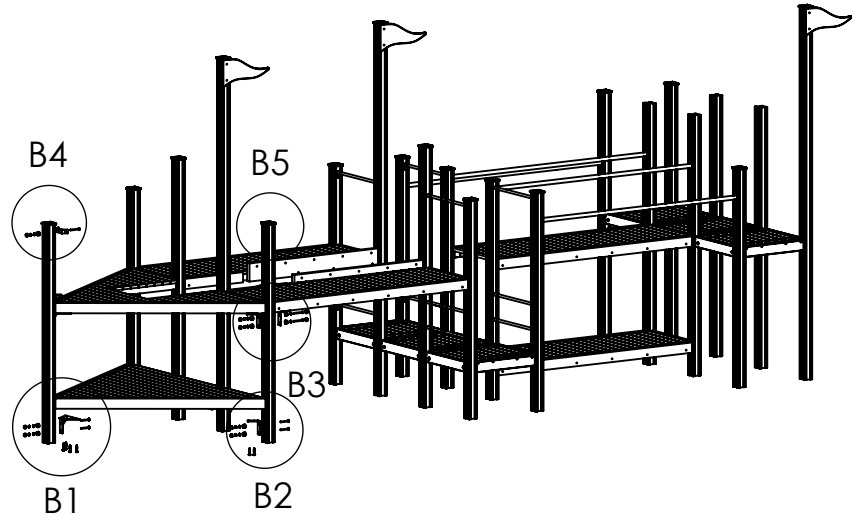

DETAIL B1 SCALE 1 : 15

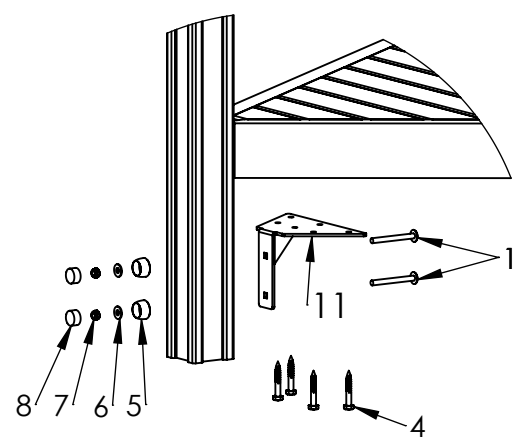

DETAIL B2 SCALE 1 : 15

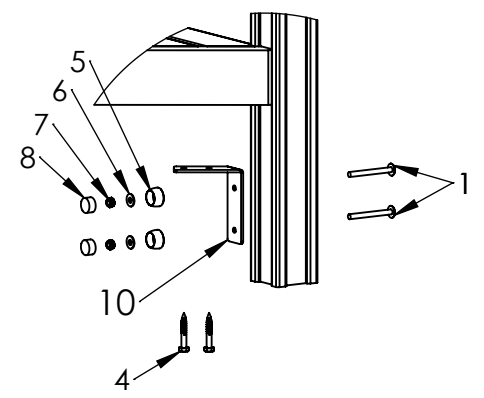

ITEM NO.	PART NUMBER
1	bolt M10x100 DIN603
2	bolt M10x110 DIN603
3	bolt M10x110 DIN931
4	wide head wood screw 10x60
5	nut cover M12
6	washer M10 DIN9054
7	nut M10 DIN985
8	nut cover cap M12
9	panel fixing V-shape
10	corner 34°, 150x135
11	platform fixing

UNLESS OTHERWISE SPECIFIED:
DIMENSIONS ARE IN MILLIMETERS
WEIGHT ARE IN KILOGRAMM

	NAME	SIGNATURE	DATE	REVISION
DRAWN	M.Rebase		31.03.2022	
APPV'D				



PART NUMBER / DWG NO.: MM118	
DESCRIPTION: Playship NOA connecting platform to post	
MATERIAL:	A4
WEIGHT:	SCALE: 1:80 SHEET 18 OF 40

A

B

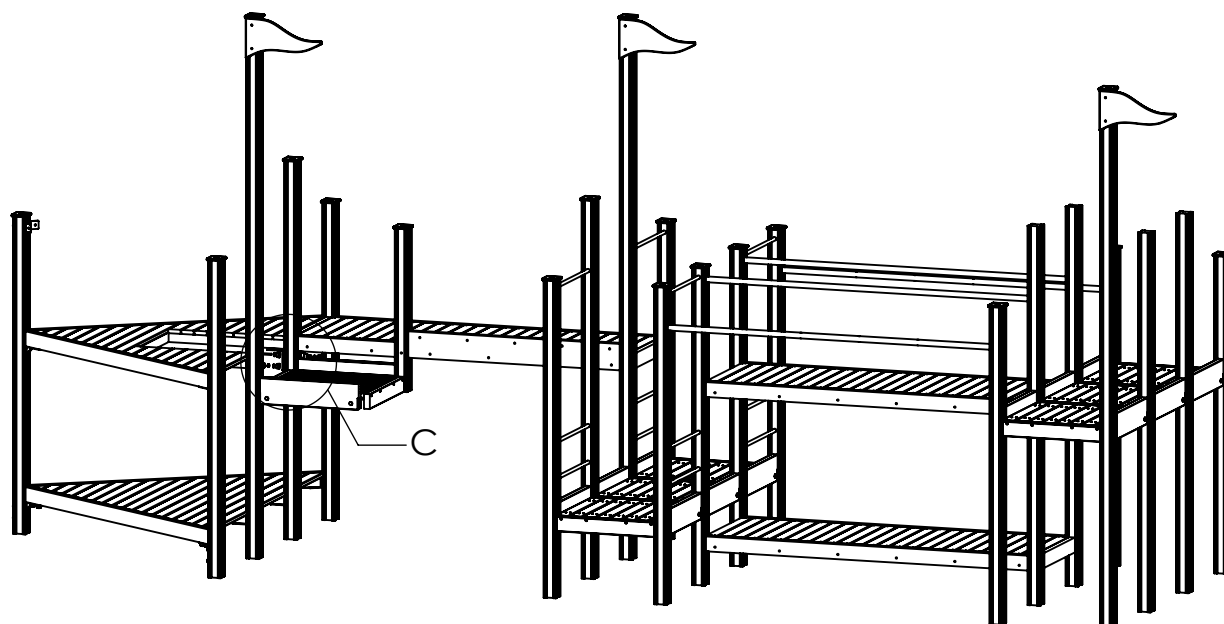

DETAIL C
SCALE 1 : 8

C

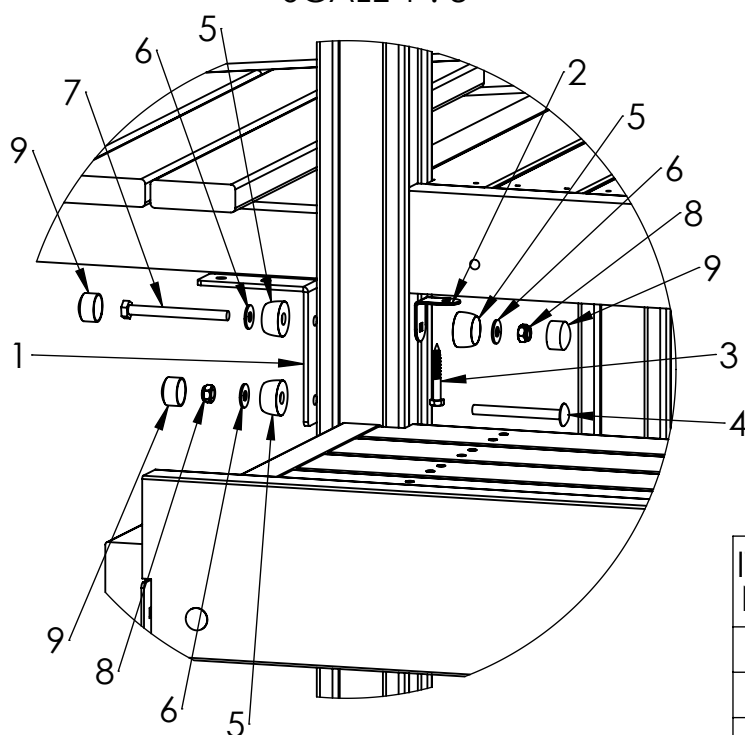

D

E

ITEM NO.	PART NUMBER
1	corner 125x150x45
2	corner 45x45
3	wide head wood screw 8x60
4	bolt M10x100 DIN603
5	nut cover M12
6	washer M10 DIN9054
7	bolt M10x110 DIN931
8	nut M10 DIN985
9	nut cover cap M12

UNLESS OTHERWISE SPECIFIED:
DIMENSIONS ARE IN MILLIMETERS
WEIGHT ARE IN KILOGRAMM

PART NUMBER / DWG NO.:

MM118

NAME	SIGNATURE	DATE	REVISION
DRAWN M.Rebase		31.03.2022	
APPV'D			

DESCRIPTION:

Playship NOA

MATERIAL:

A4

WEIGHT:

SCALE: 1:55

SHEET 19 OF 40



Tiptap OÜ

A

B

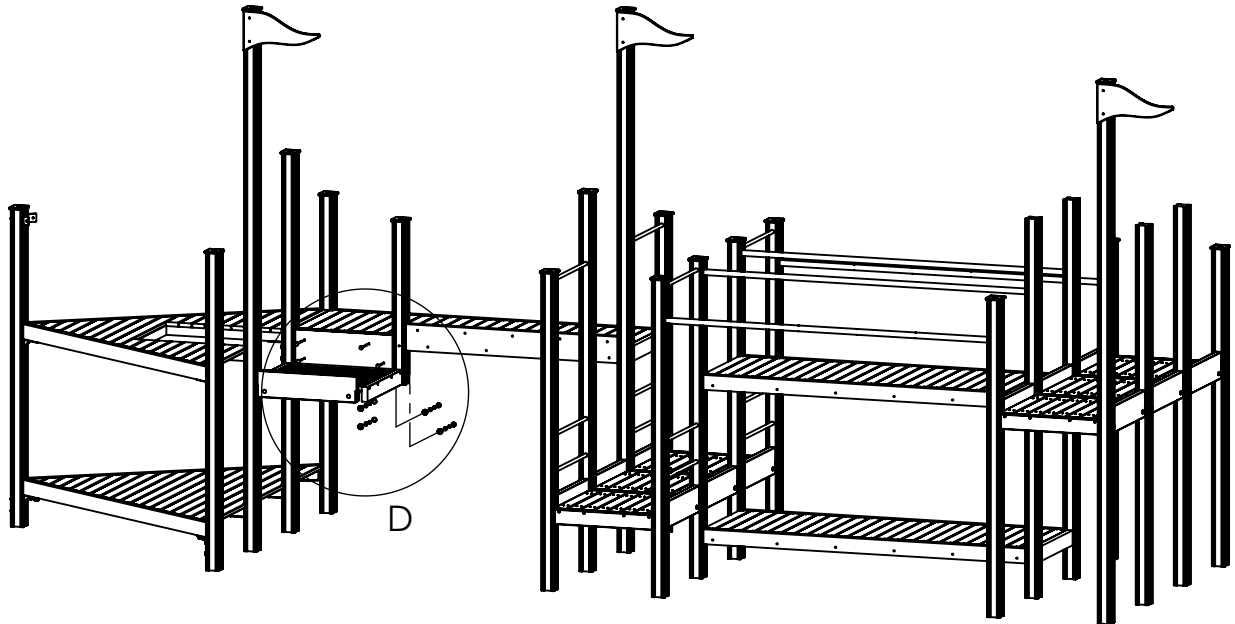

C

DETAIL D
SCALE 1 : 15

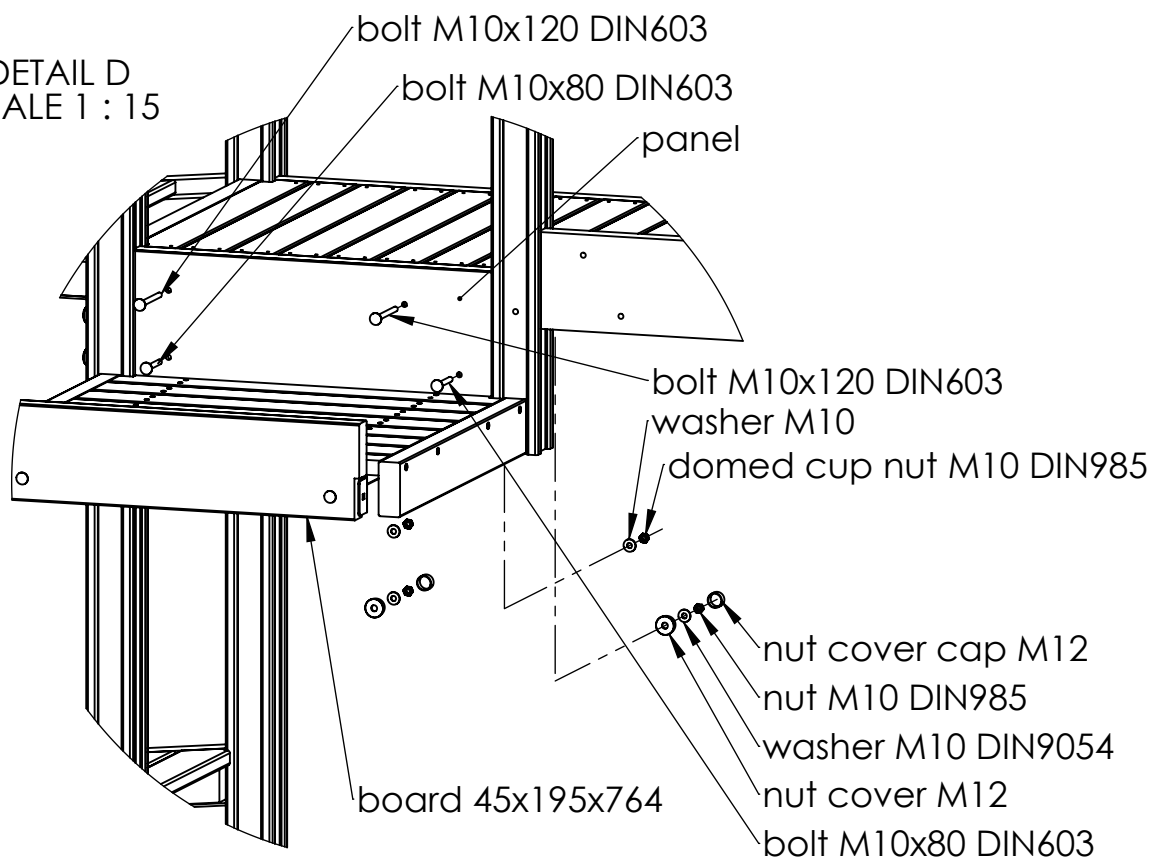

D

E

F

UNLESS OTHERWISE SPECIFIED: DIMENSIONS ARE IN MILLIMETERS WEIGHT ARE IN KILOGRAMM				
	NAME	SIGNATURE	DATE	REVISION
DRAWN	M.Rebase		31.03.2022	
APPV'D				

PART NUMBER / DWG NO.:	MM118
DESCRIPTION:	Playship NOA



Tiptiptap OÜ

MATERIAL:	A4
WEIGHT:	SCALE: 1:55
	SHEET 20 OF 40

A

B

C

D

E

F

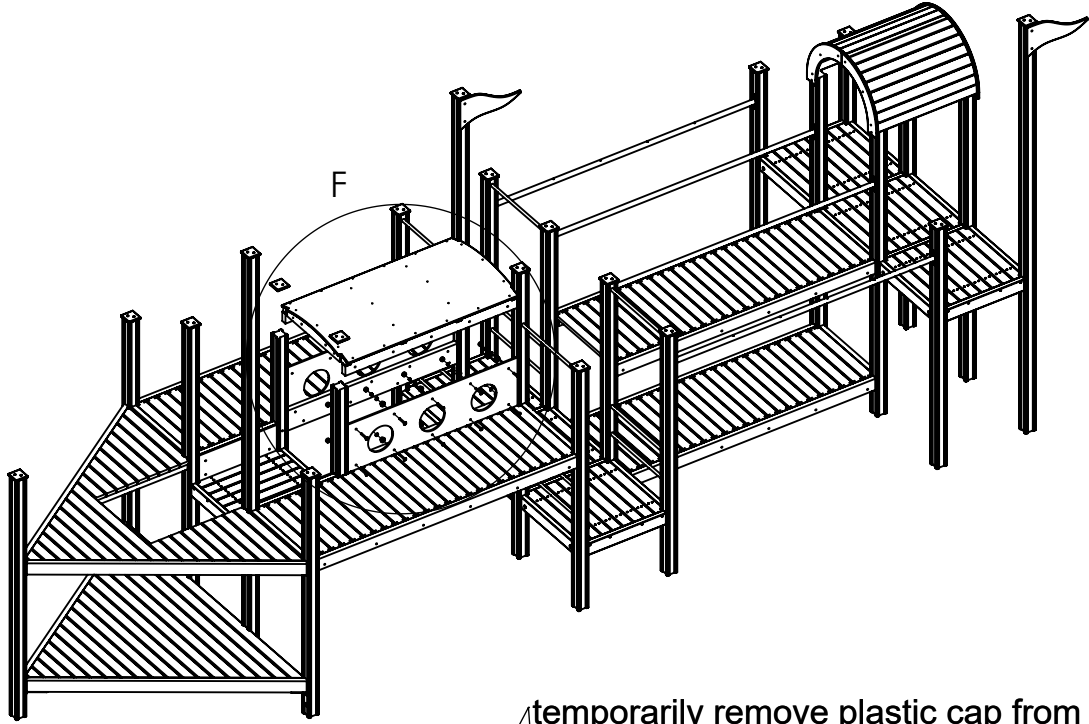

F

temporarily remove plastic cap from the post

DETAIL F
SCALE 1 : 20

nut cover cap M12

nut M10 DIN985

washer M10 DIN9054

nut cover M12

bolt M10x80 DIN603

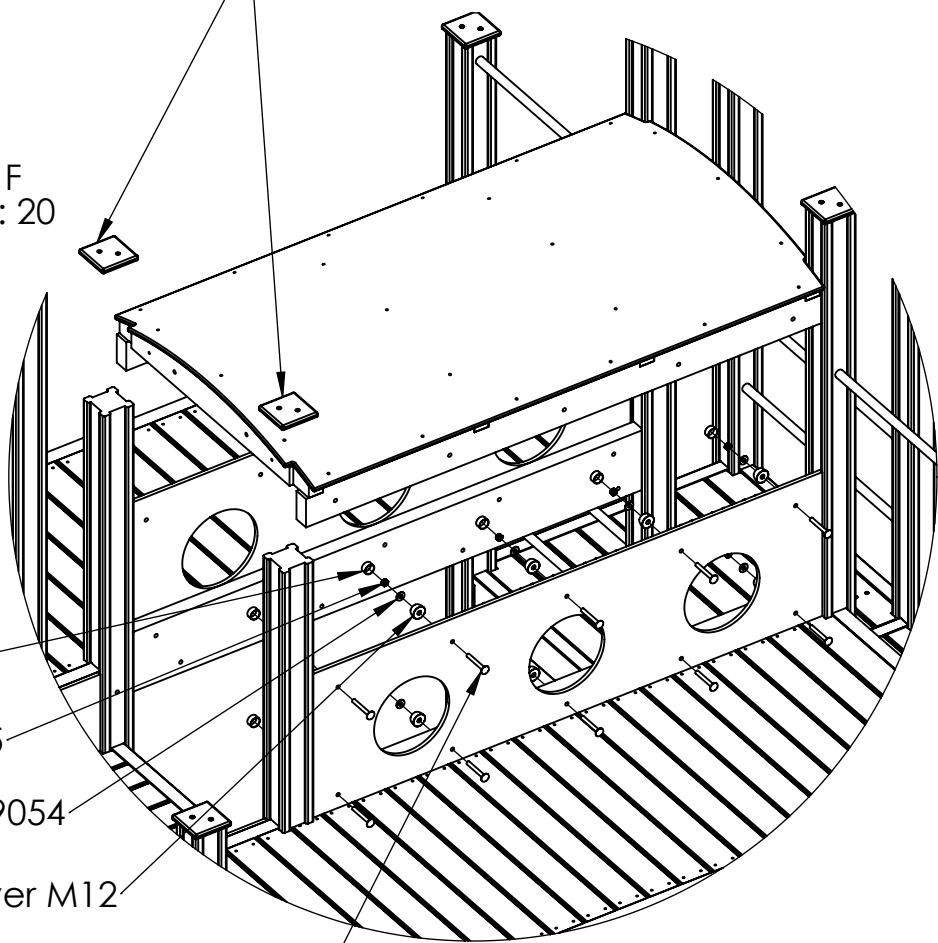

UNLESS OTHERWISE SPECIFIED:
DIMENSIONS ARE IN MILLIMETERS
WEIGHT ARE IN KILOGRAMM

PART NUMBER / DWG NO.:
MM118

	NAME	SIGNATURE	DATE	REVISION
DRAWN	M.Rebase		31.03.2022	
APPV'D				

DESCRIPTION:
Playship NOA



Tiptiptap OÜ

MATERIAL:
A4

WEIGHT: SCALE: 1:60 SHEET 21 OF 40

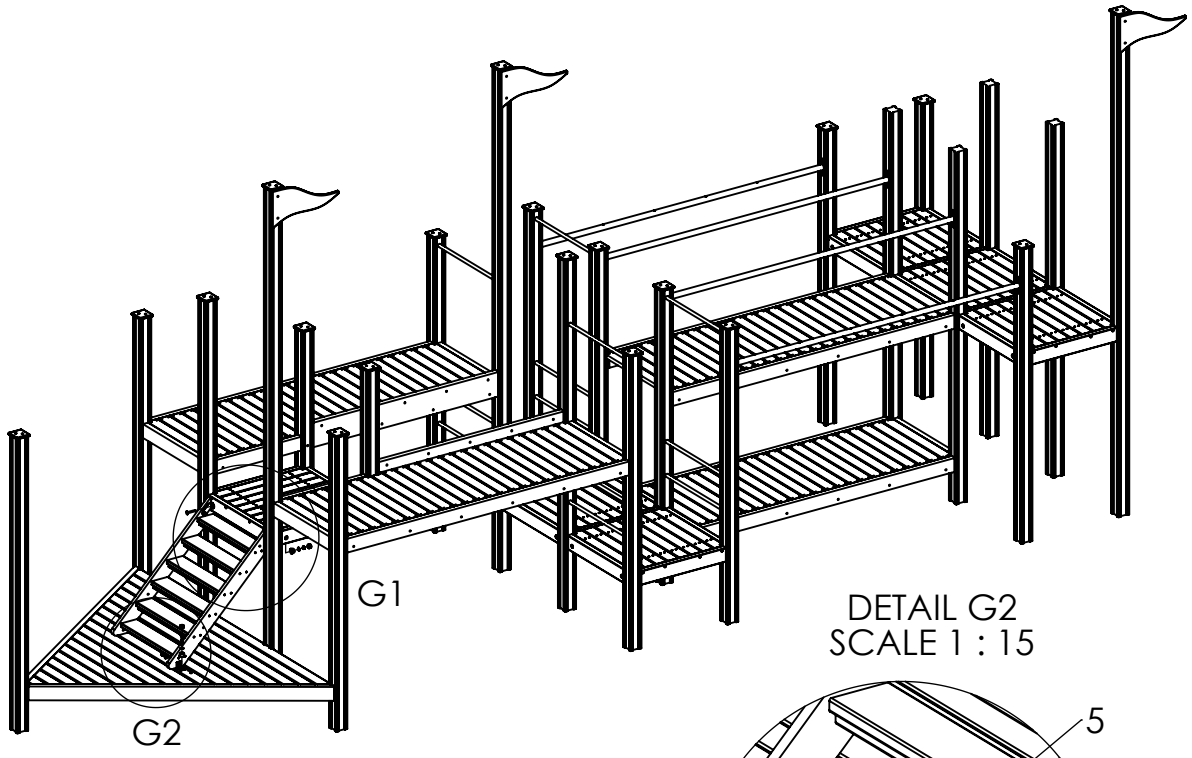

DETAIL G1
SCALE 1 : 15

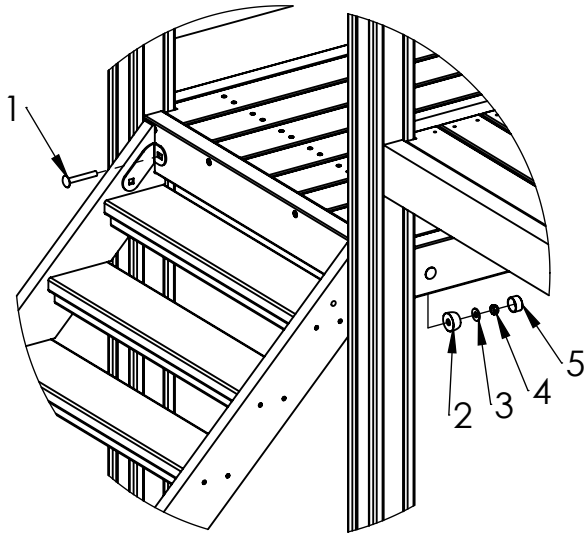

DETAIL G2
SCALE 1 : 15

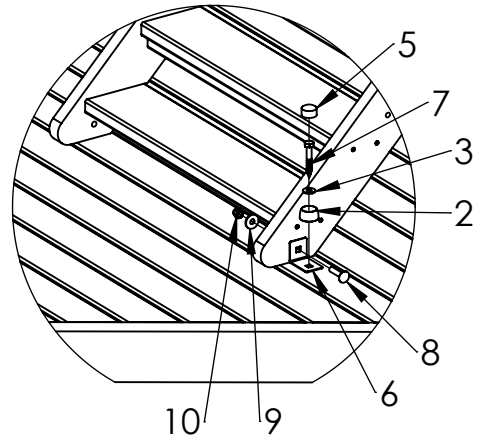

ITEM NO.	PART NUMBER
1	bolt M10x70 DIN603
2	nut cover M12
3	washer M10 DIN9054
4	nut M10 DIN985
5	nut cover cap M12
6	corner 45x60
7	wood screw 10x70 DIN571
8	bolt M10x45 DIN603
9	washer M10 DIN9021
10	domed cap nut M10 DIN986

UNLESS OTHERWISE SPECIFIED:
DIMENSIONS ARE IN MILLIMETERS
WEIGHT ARE IN KILOGRAMM

PART NUMBER / DWG NO.:

MM118

	NAME	SIGNATURE	DATE	REVISION
DRAWN	M.Rebase		31.03.2022	
APPV'D				

DESCRIPTION:

Playship NOA



Tiptap OÜ

MATERIAL:

A4

WEIGHT:

SCALE: 1:55

SHEET 22 OF 40

A

B

C

D

E

F

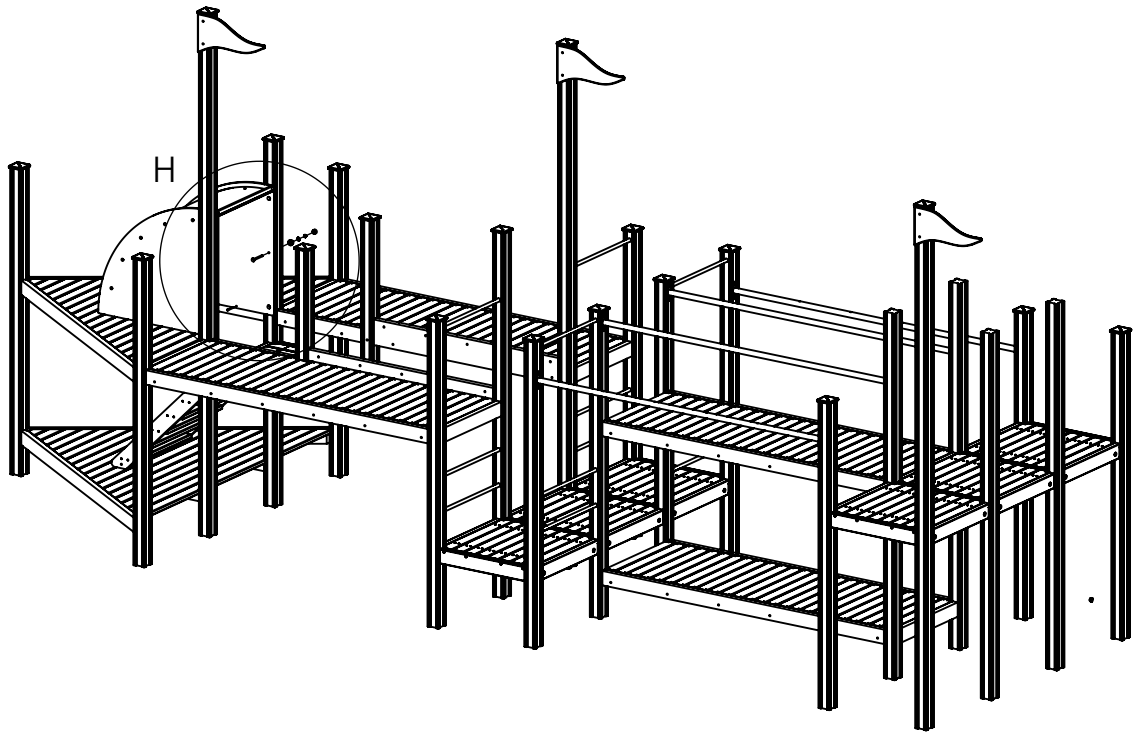

DETAIL H
SCALE 1 : 15

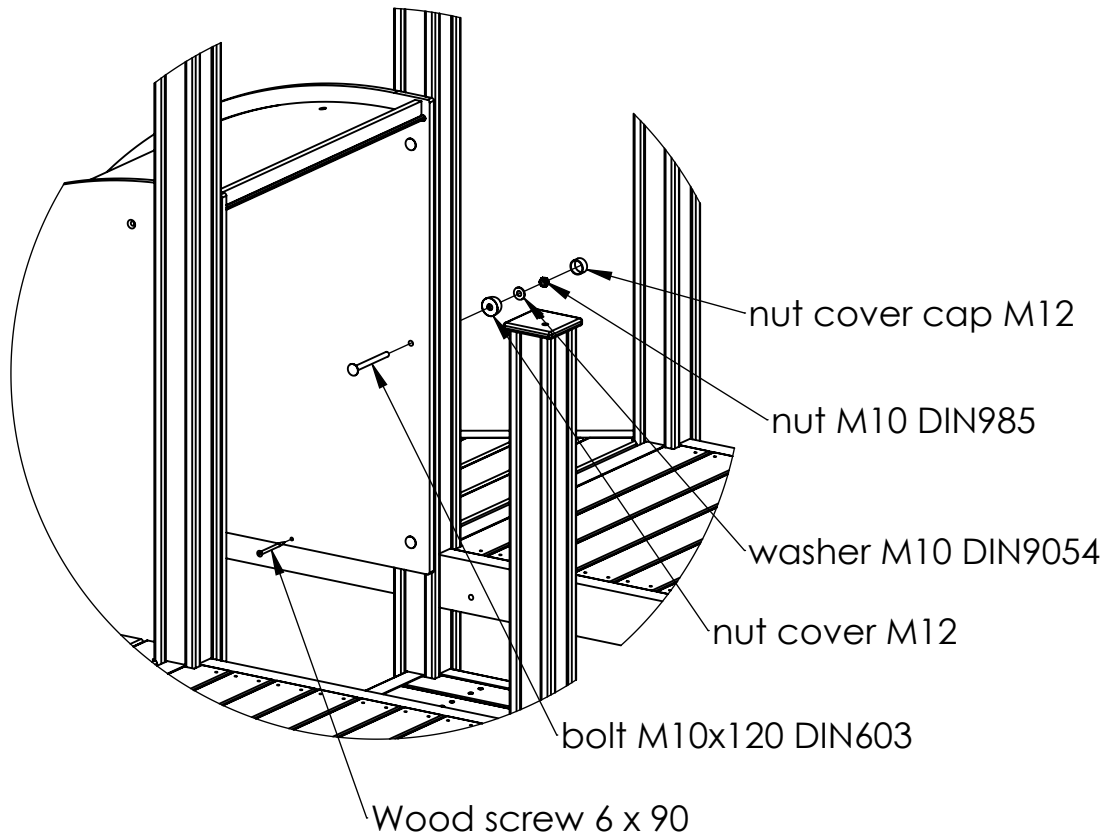

nut cover cap M12

nut M10 DIN985

washer M10 DIN9054

nut cover M12

bolt M10x120 DIN603

Wood screw 6 x 90

UNLESS OTHERWISE SPECIFIED:
DIMENSIONS ARE IN MILLIMETERS
WEIGHT ARE IN KILOGRAMM

PART NUMBER / DWG NO.:

MM118

	NAME	SIGNATURE	DATE	REVISION
DRAWN	M.Rebase		31.03.2022	
APPV'D				

DESCRIPTION:

Playship NOA



Tiptap OÜ

MATERIAL:

A4

WEIGHT:

SCALE: 1:55

SHEET 23 OF 40

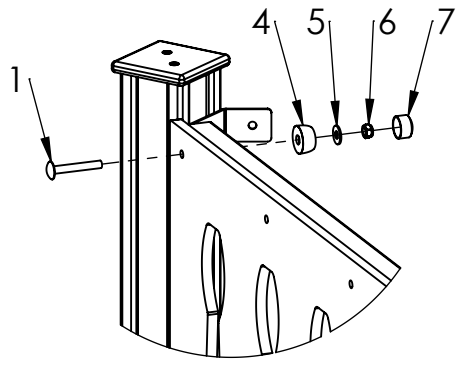

DETAIL 11
SCALE 1 : 10

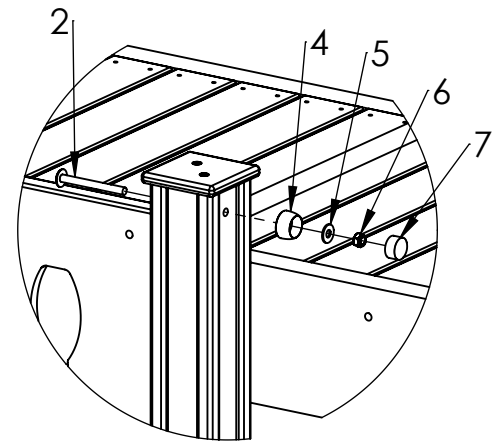

DETAIL 13
SCALE 1 : 10

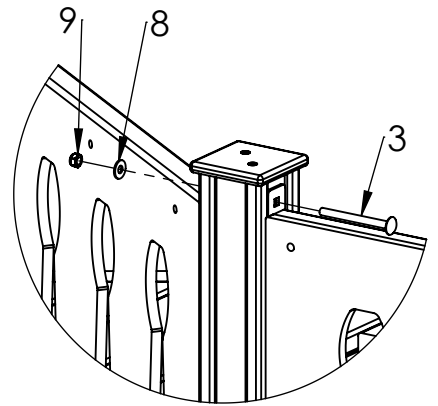

DETAIL 12
SCALE 1 : 10

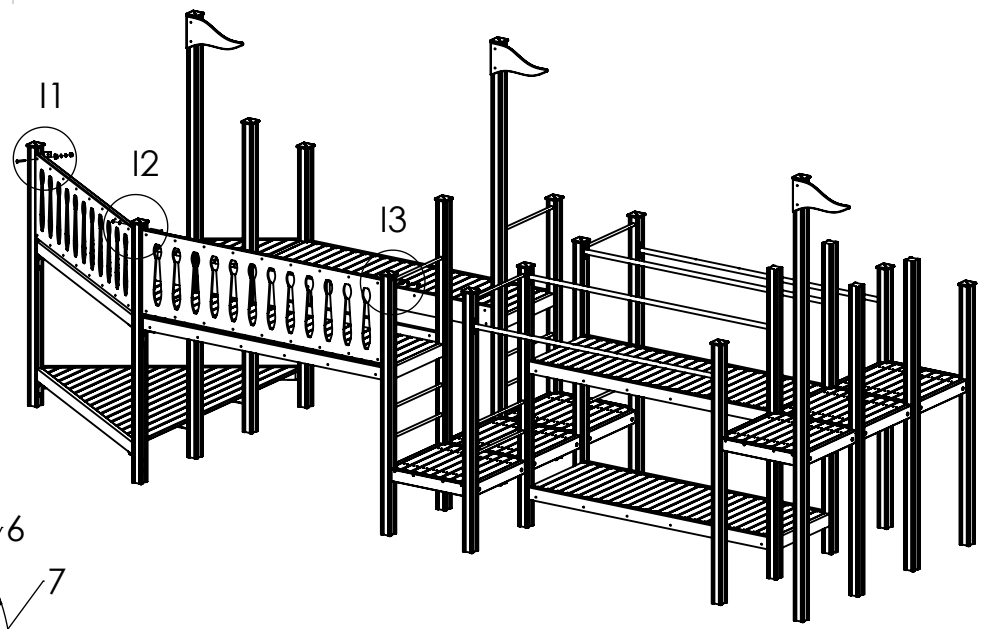

ITEM NO.	PART NUMBER
1	bolt M10x70 DIN603
2	bolt M10x100 DIN603
3	bolt M10x110 DIN603
4	nut cover M12
5	washer M10 DIN9054
6	nut M10 DIN985
7	nut cover cap M12
8	washer M10 DIN125
9	domed cap nut M10 DIN986

UNLESS OTHERWISE SPECIFIED:
DIMENSIONS ARE IN MILLIMETERS
WEIGHT ARE IN KILOGRAMM

	NAME	SIGNATURE	DATE	REVISION
DRAWN	M.Rebase		31.03.2022	
APPV'D				

PART NUMBER / DWG NO.:		MM118	
DESCRIPTION:		Playship NOA	
MATERIAL:		A4	
WEIGHT:	SCALE: 1:65	SHEET 24 OF 40	



A

B

C

D

E

F

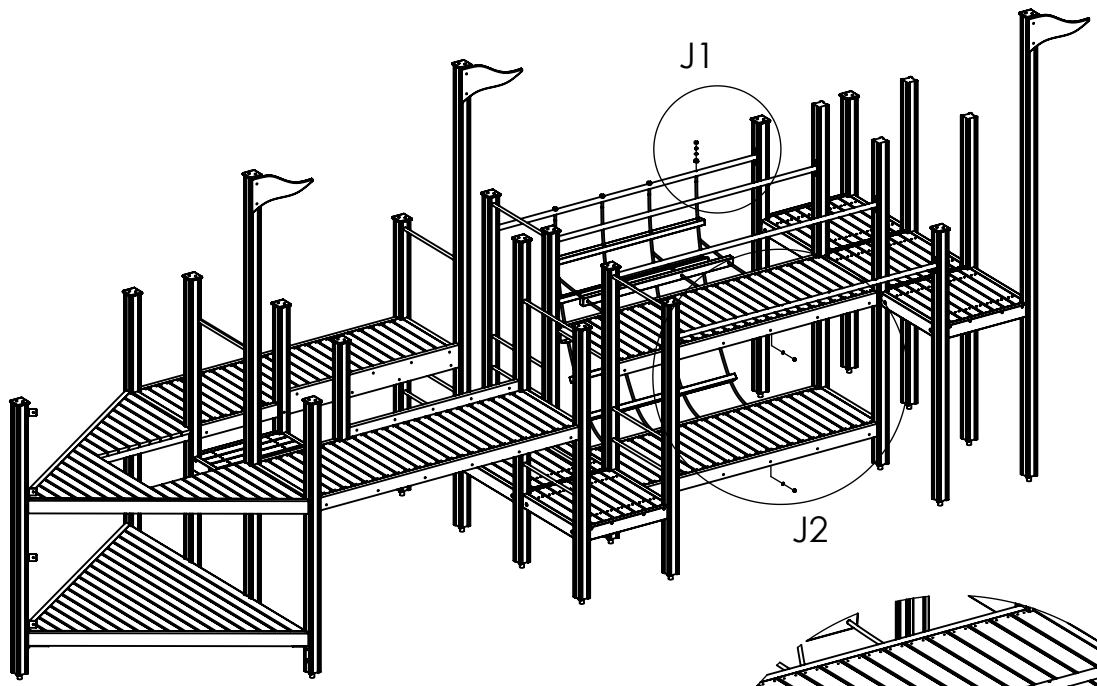

DETAIL J1
SCALE 1 : 30

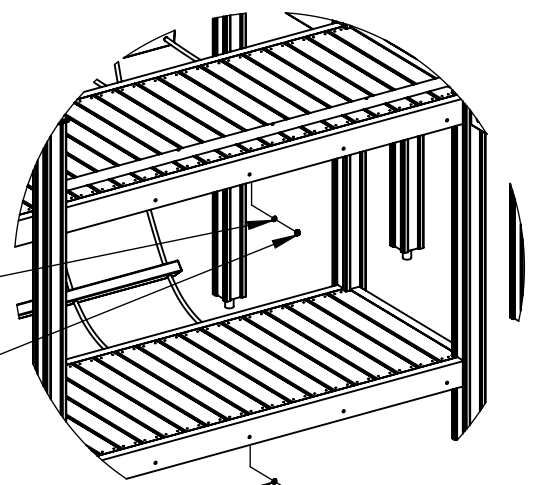
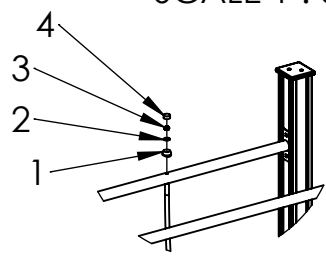

DETAIL J2
SCALE 1 : 30

The use of thread adhesive is necessary

ITEM NO.	PART NUMBER
1	nut cover M12 for beam
2	washer M10 DIN9054
3	nut M10 DIN985
4	nut cover cap M12
5	washer M10 DIN9021
6	nut M10 DIN986

UNLESS OTHERWISE SPECIFIED:
DIMENSIONS ARE IN MILLIMETERS
WEIGHT ARE IN KILOGRAMM

	NAME	SIGNATURE	DATE	REVISION
DRAWN	M.Rebase		31.03.2022	
APPV'D				

PART NUMBER / DWG NO.:
MM118

DESCRIPTION:
Playship NOA



Tiptiptap OÜ

MATERIAL:	A4
WEIGHT:	SCALE: 1:60
	SHEET 25 OF 40

A

B

C

D

E

F

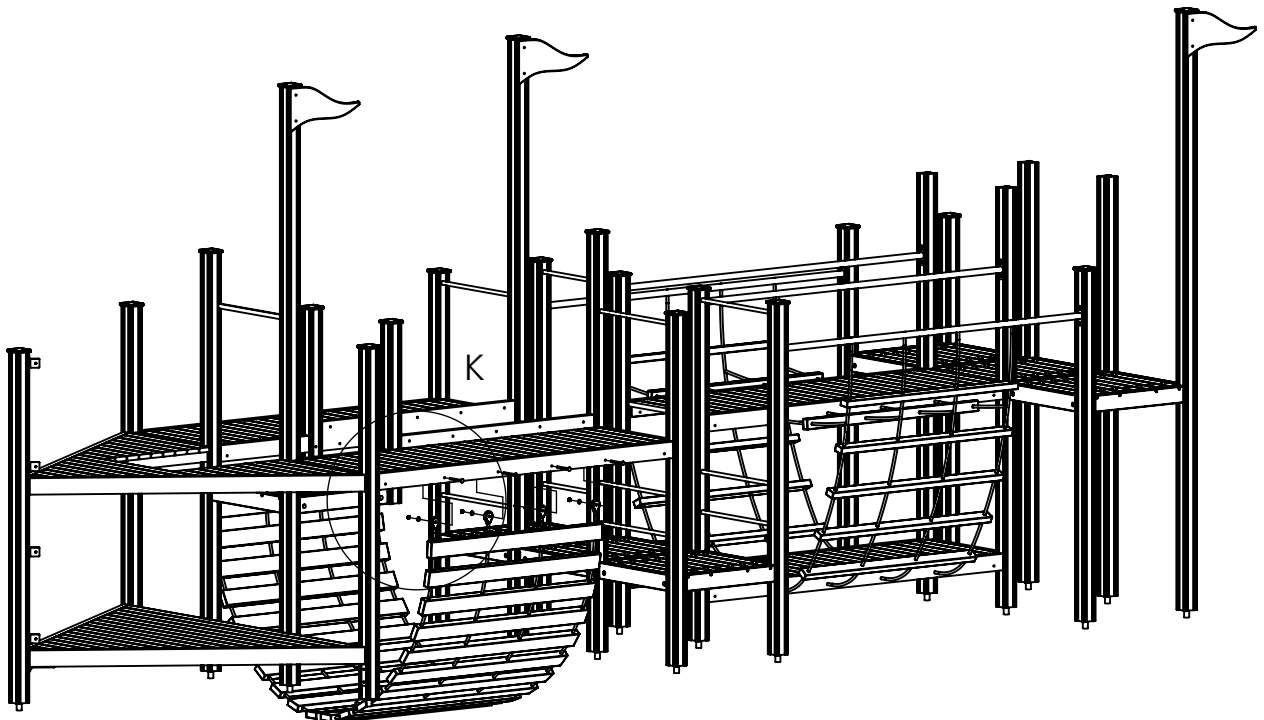

DETAIL K
SCALE 1 : 15

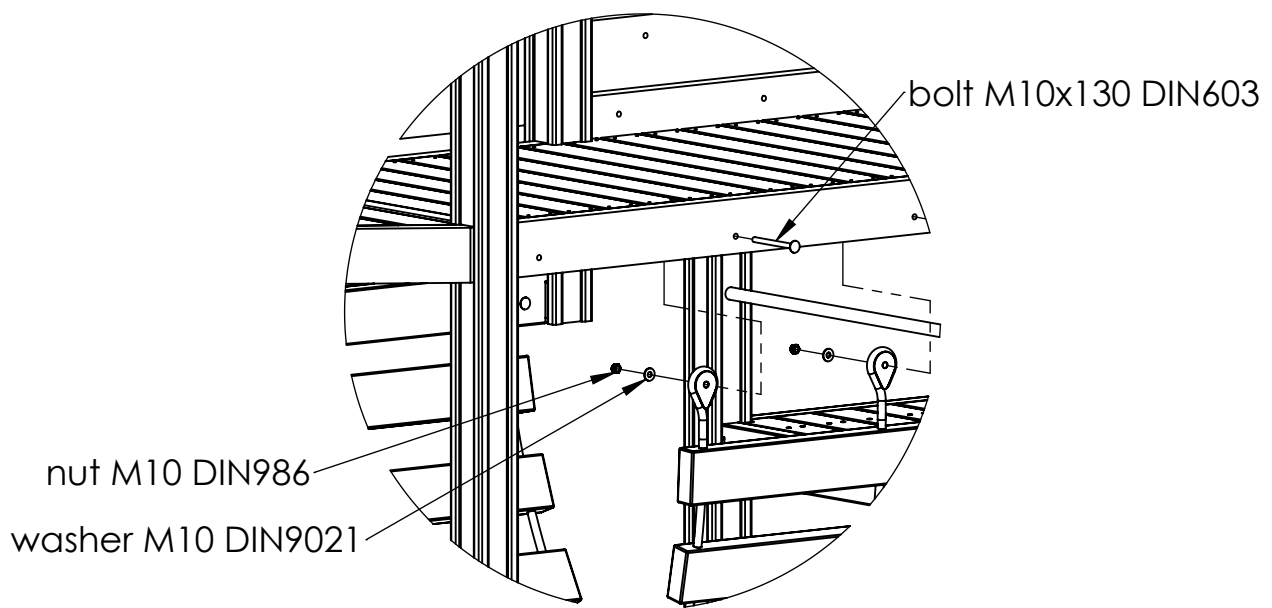

The use of thread adhesive is necessary

UNLESS OTHERWISE SPECIFIED: DIMENSIONS ARE IN MILLIMETERS WEIGHT ARE IN KILOGRAMM				
	NAME	SIGNATURE	DATE	REVISION
DRAWN	M.Rebase		31.03.2022	
APPV'D				

PART NUMBER / DWG NO.:	MM118
DESCRIPTION:	Playship NOA



Tiptap OÜ

MATERIAL:	A4
WEIGHT:	SCALE: 1:50
	SHEET 26 OF 40

A

B

C

D

E

F

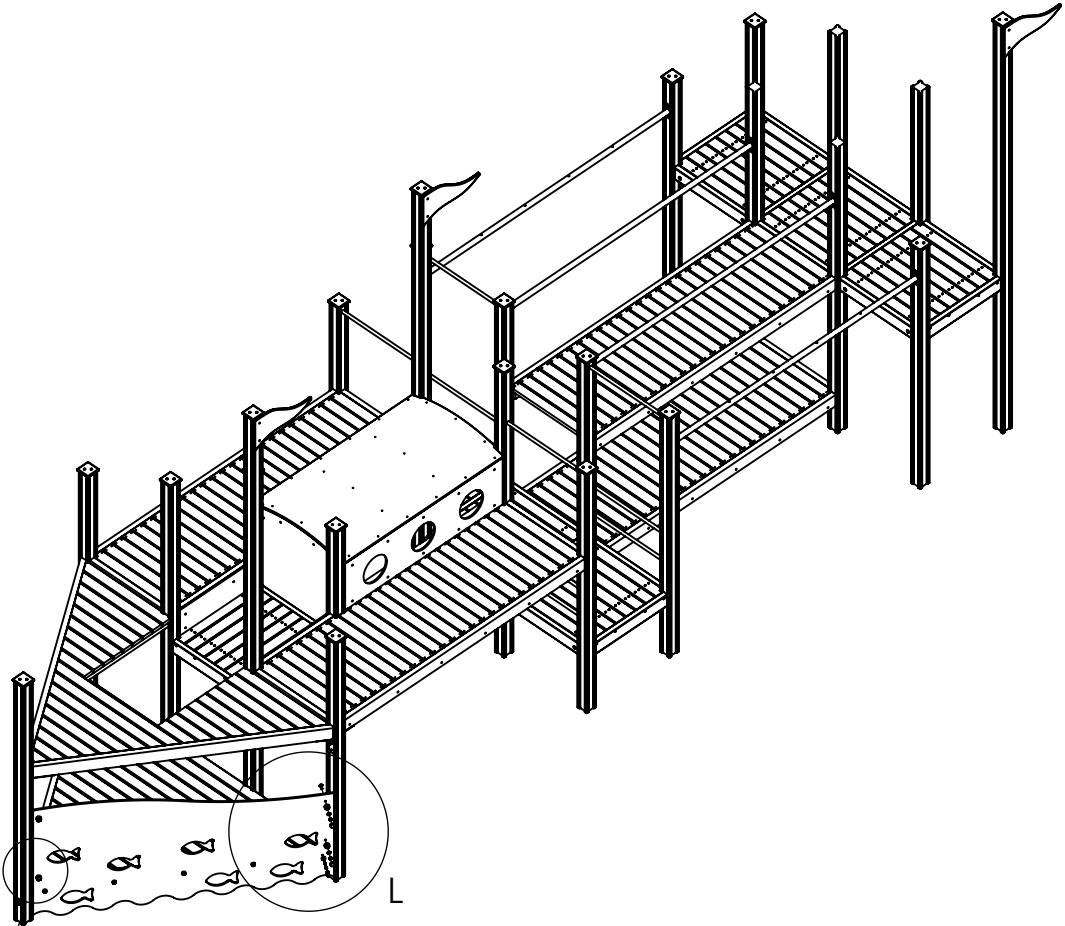

DETAIL L
SCALE 1 : 17

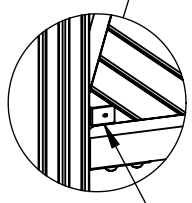

panel fixing
V-shape

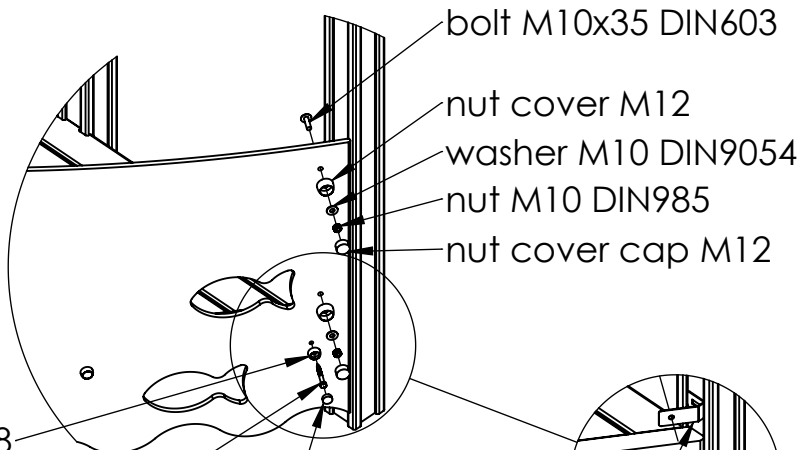

bolt M10x35 DIN603

nut cover M12

washer M10 DIN9054

nut M10 DIN985

nut cover cap M12

nut cover M8

wood screw 8x70 DIN571

nut cover cap M8

panel fixing
corner 34°

UNLESS OTHERWISE SPECIFIED:
DIMENSIONS ARE IN MILLIMETERS
WEIGHT ARE IN KILOGRAMM

PART NUMBER / DWG NO.:
MM118

	NAME	SIGNATURE	DATE	REVISION
DRAWN	M.Rebase		31.03.2022	
APPV'D				

DESCRIPTION:
Playship NOA



Tiptap OÜ

MATERIAL:
A4

WEIGHT: SCALE: 1:55 SHEET 27 OF 40

A

B

C

D

E

F

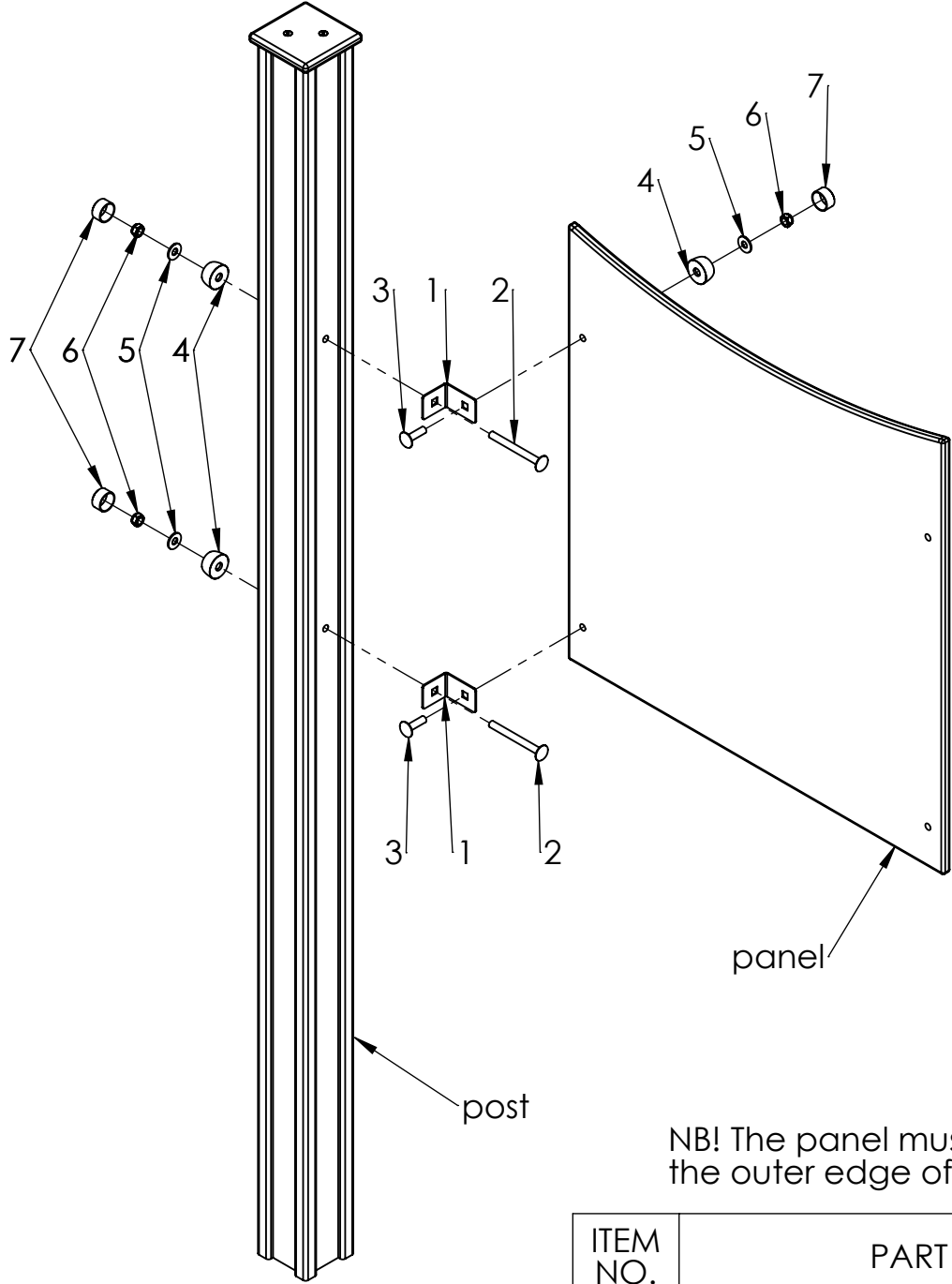

panel

post

NB! The panel must be attached to the outer edge of the post !

ITEM NO.	PART NUMBER
1	corner 48x60
2	bolt M10x100 DIN603
3	bolt M10x35 DIN603
4	nut cover M12
5	washer M10 DIN9054
6	nut M10 DIN985
7	nut cover cap M12

UNLESS OTHERWISE SPECIFIED: DIMENSIONS ARE IN MILLIMETERS WEIGHT ARE IN KILOGRAMM				
	NAME	SIGNATURE	DATE	REVISION
DRAWN	M.Rebase		31.03.2022	
APPV'D				

PART NUMBER / DWG NO.:
MM118

DESCRIPTION:
**Playship NOA
connecting panel to post**



Tiptap OÜ

MATERIAL:	A4
WEIGHT:	SCALE: 1:10
	SHEET 28 OF 40

A

Explanation of the `lower hole` behind the panel name:

B

C

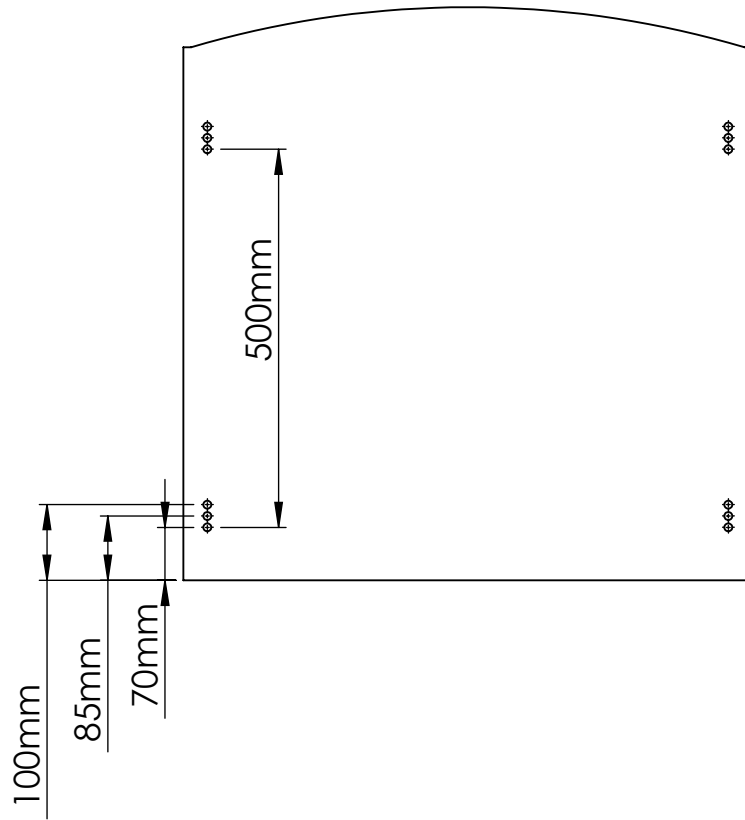

D

The panel must be installed on the post as shown in the picture!

E

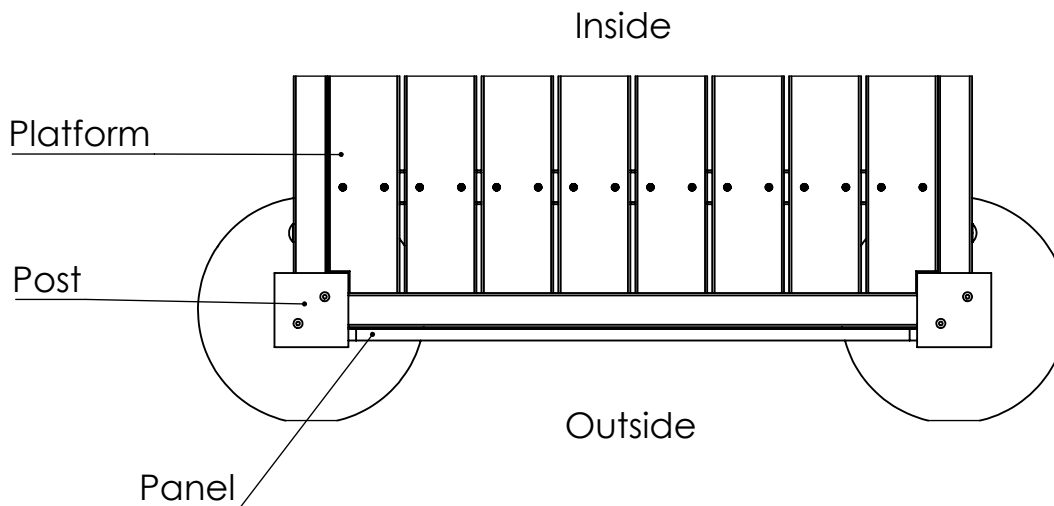

F

UNLESS OTHERWISE SPECIFIED:
DIMENSIONS ARE IN MILLIMETERS
WEIGHT ARE IN KILOGRAMM

PART NUMBER / DWG NO.:

MM118

	NAME	SIGNATURE	DATE	REVISION
DRAWN	M.Rebase		31.03.2022	
APPV'D				

DESCRIPTION:

Playship NOA



Tiptiptap OÜ

MATERIAL:

A4

WEIGHT:

SCALE: 1:10

SHEET 29 OF 40

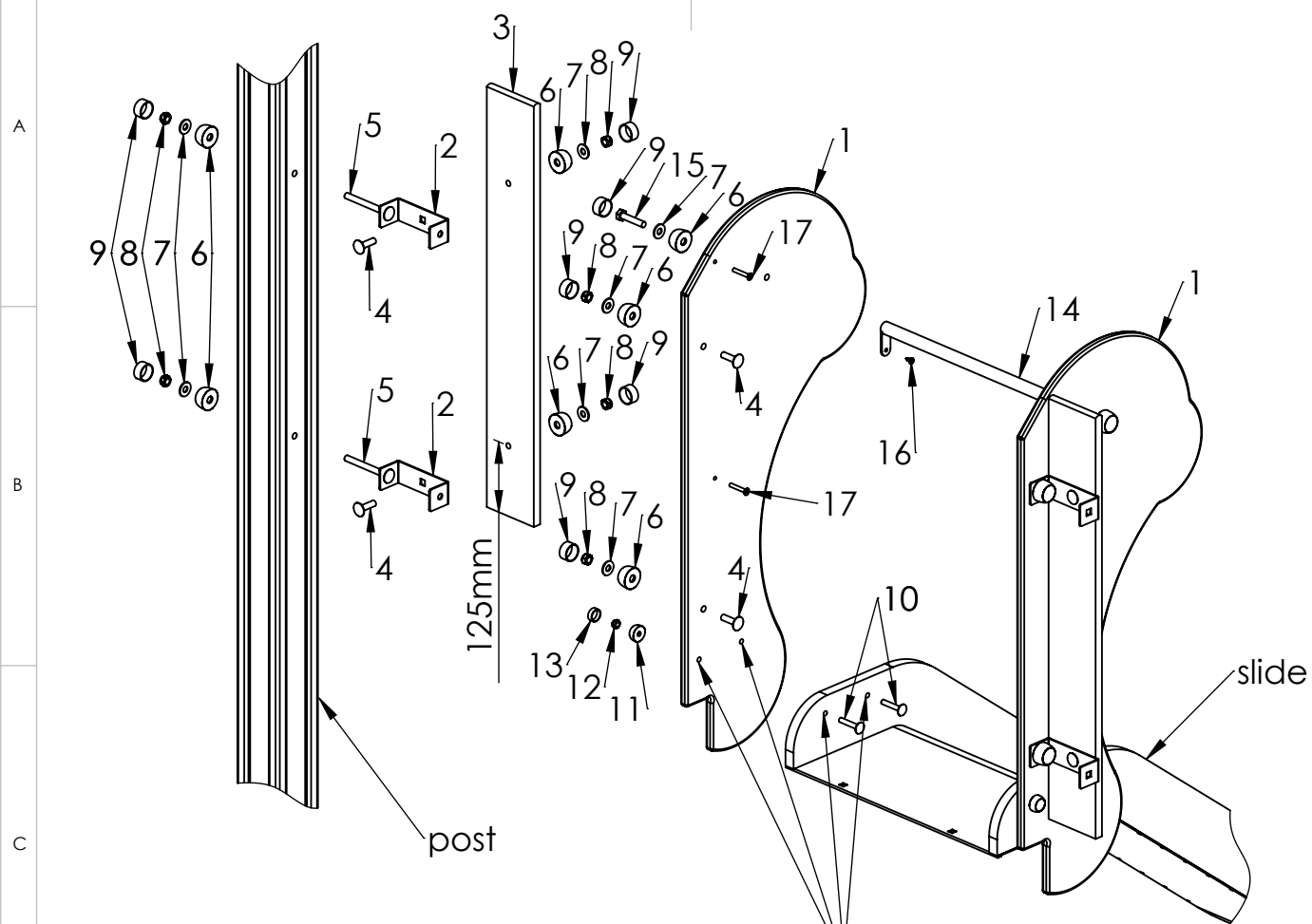

It is important to drill 8,5mm holes through side panel and slide.

ITEM NO.	PART NUMBER
1	slide side panel
2	slide side panel fixing 40x120
3	side panel 111x770
4	bolt M10x35 DIN603
5	bolt M10x100 DIN603
6	nut cover M12
7	washer M10 DIN9054
8	nut M10 DIN985
9	nut cover cap M12
10	bolt M8x45 DIN603
11	nut cover M8
12	nut M8 DIN985
13	nut cover cap M8
14	slide guardrail
15	bolt M10x50 DIN931
16	wood screw 4,8x13
17	metal screw M6x35

UNLESS OTHERWISE SPECIFIED:
DIMENSIONS ARE IN MILLIMETERS
WEIGHT ARE IN KILOGRAMM

PART NUMBER / DWG NO.:

MM118

	NAME	SIGNATURE	DATE	REVISION
DRAWN	M.Rebase		31.03.2022	
APPV'D				

DESCRIPTION:

Playship NOA
connecting silde quard block to post

MATERIAL:

A4

WEIGHT:

SCALE: 1:12

SHEET 30 OF 40



Tiptap OÜ

A

B

C

D

E

F

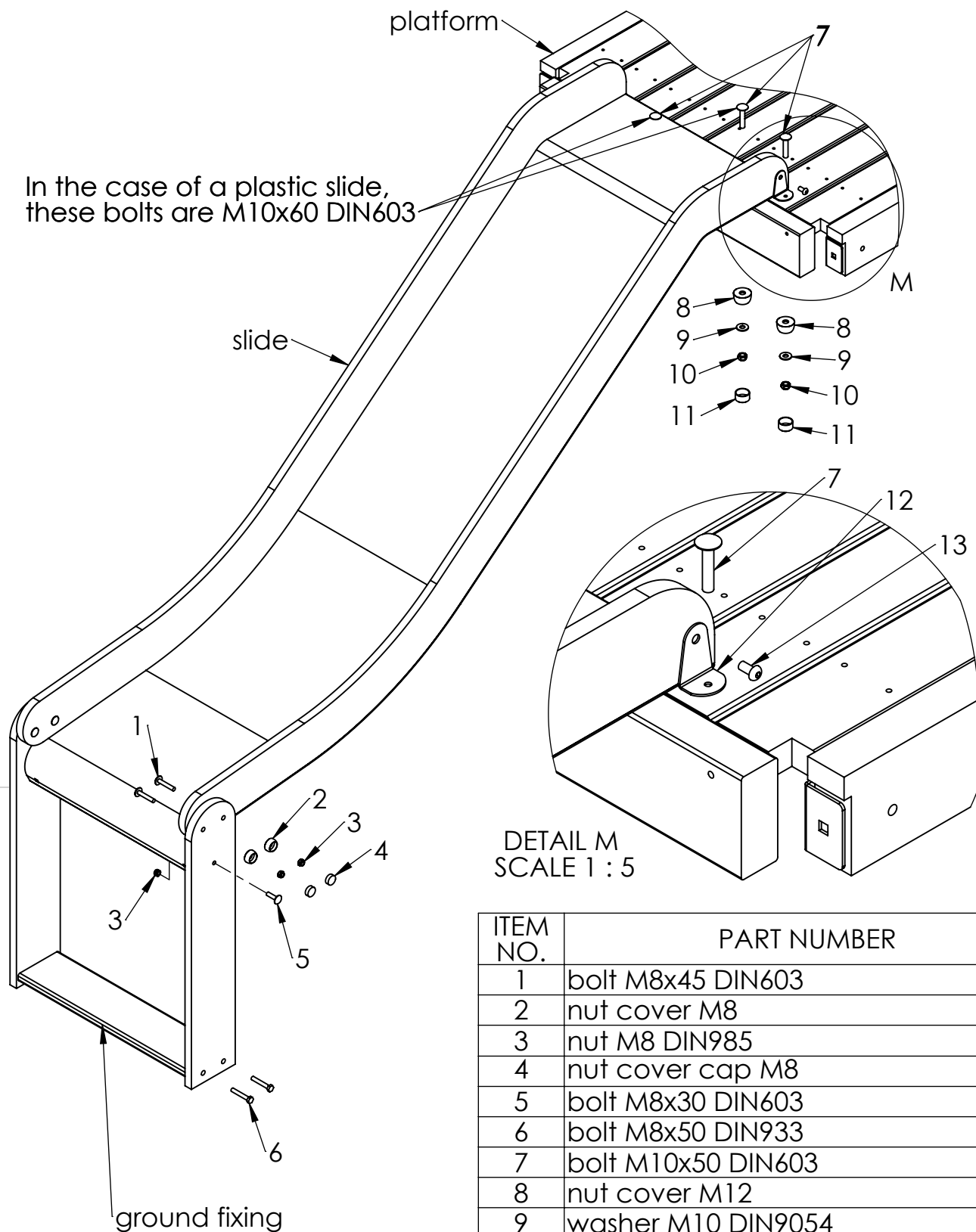

ITEM NO.	PART NUMBER
1	bolt M8x45 DIN603
2	nut cover M8
3	nut M8 DIN985
4	nut cover cap M8
5	bolt M8x30 DIN603
6	bolt M8x50 DIN933
7	bolt M10x50 DIN603
8	nut cover M12
9	washer M10 DIN9054
10	nut M10 DIN985
11	nut cover cap M12
12	corner 58x30
13	metal screw M8x16 DIN7380

UNLESS OTHERWISE SPECIFIED:
DIMENSIONS ARE IN MILLIMETERS
WEIGHT ARE IN KILOGRAMM

	NAME	SIGNATURE	DATE	REVISION
DRAWN	M.Rebase		31.03.2022	
APPV'D				

PART NUMBER / DWG NO.:

MM118

DESCRIPTION:

Playship NOA
connecting slide to platform

MATERIAL:

A4

WEIGHT:

SCALE: 1:12

SHEET 31 OF 40



Tiptap OÜ

A

B

C

D

E

F

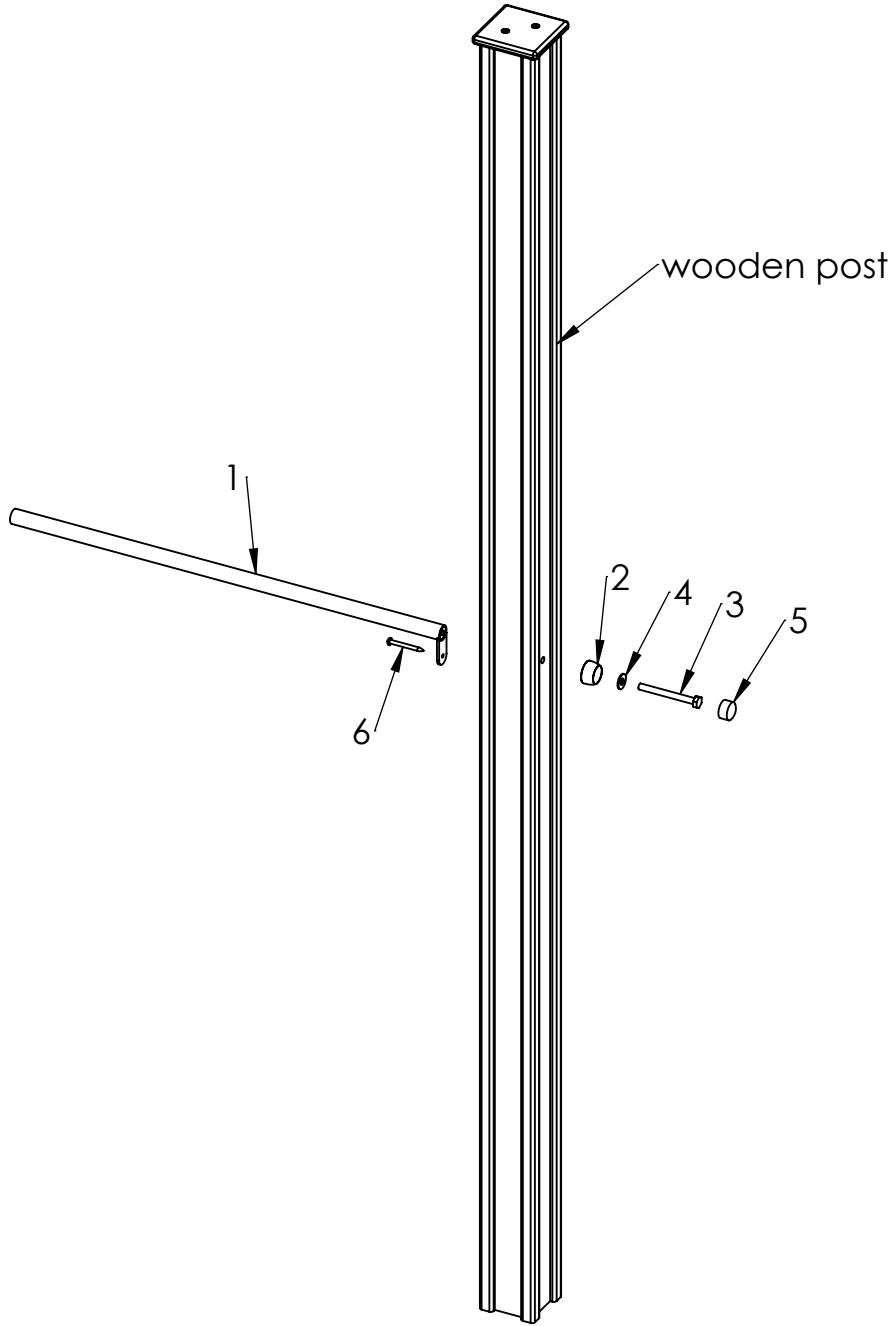

ITEM NO.	PART NUMBER
1	guardrail ϕ 25x770
2	nut cover M12
3	bolt M10x100 DIN931
4	washer M10 DIN9054
5	nut cover cap M12
6	screw 5,0x40

UNLESS OTHERWISE SPECIFIED:
 DIMENSIONS ARE IN MILLIMETERS
 WEIGHT ARE IN KILOGRAMM

	NAME	SIGNATURE	DATE	REVISION
DRAWN	M.Rebase		31.03.2022	
APPV'D				

PART NUMBER / DWG NO.:		MM118	
		connecting guardrail to post	
DESCRIPTION:		Playship NOA	
MATERIAL:		A4	
WEIGHT:	SCALE: 1:12	SHEET 32 OF 40	



Tiptiptap ^{ÖÜ}

A

B

C

D

E

F

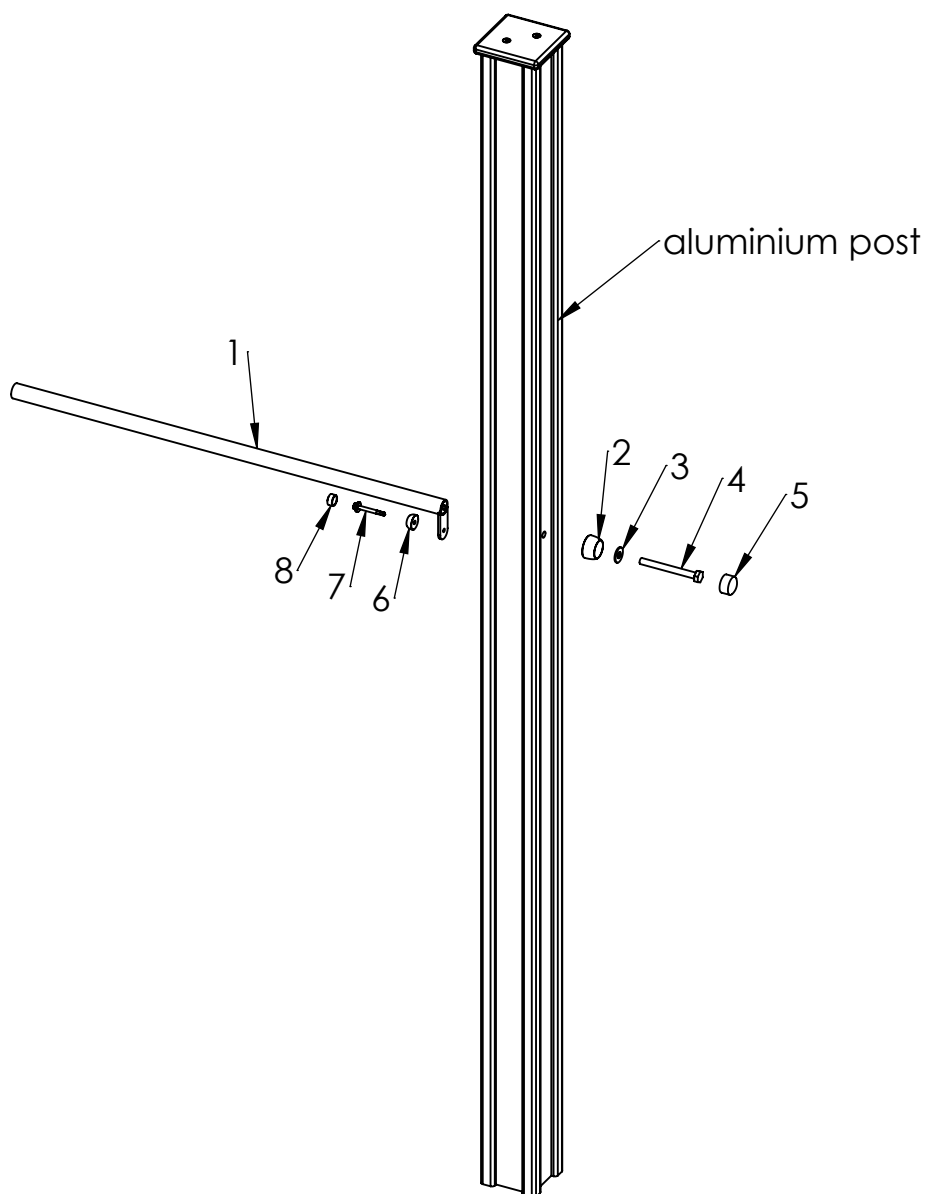

ITEM NO.	PART NUMBER
1	guardrail ϕ 25x770
2	nut cover M12
3	washer M10 DIN9054
4	bolt M10x100 DIN931
5	nut cover cap M12
6	nut cover M6
7	screw 5,5x50 DIN7504K
8	nut cover cap M6

UNLESS OTHERWISE SPECIFIED:
DIMENSIONS ARE IN MILLIMETERS
WEIGHT ARE IN KILOGRAMM

	NAME	SIGNATURE	DATE	REVISION
DRAWN	M.Rebase		31.03.2022	
APPV'D				

PART NUMBER / DWG NO.:

MM118
connecting guardrail to post

DESCRIPTION:

Playship NOA

MATERIAL:

A4

WEIGHT:

SCALE: 1:12

SHEET 33 OF 40



Tiptiptap ^{ÖÜ}

A

B

C

D

E

F

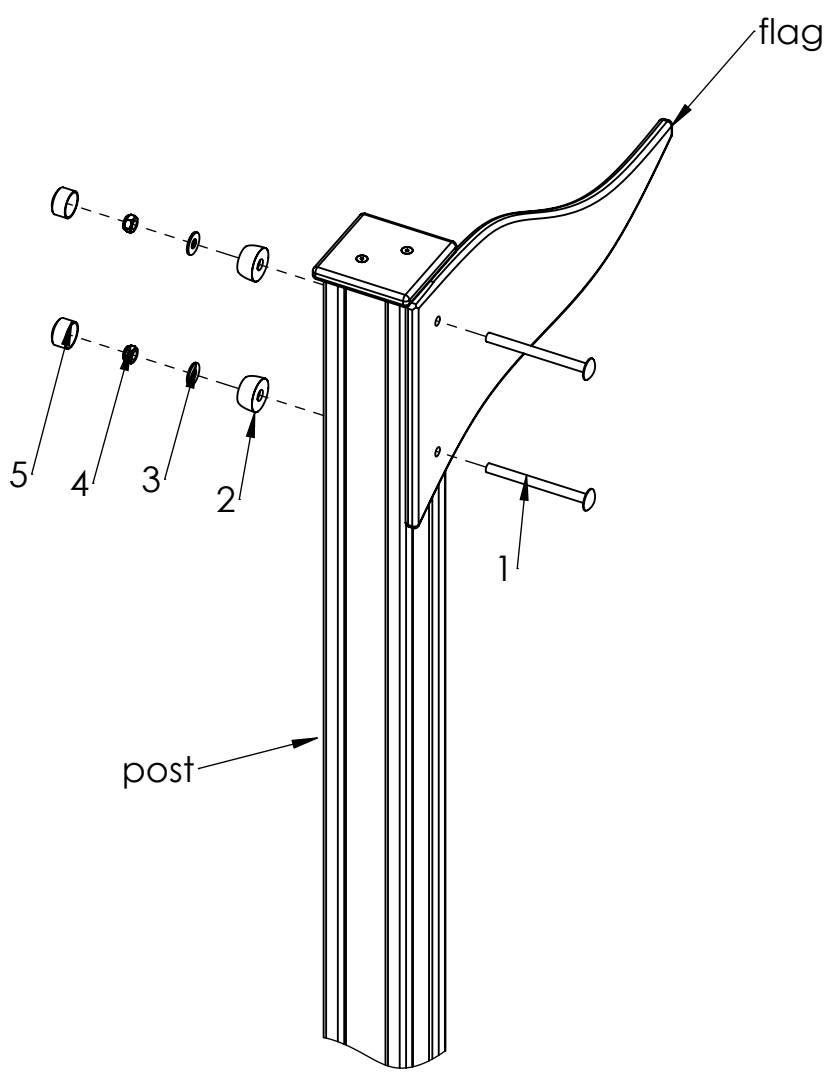

ITEM NO.	PART NUMBER
1	bolt M10x120 DIN603
2	nut cover M12
3	washer M10 DIN9054
4	nut M10 DIN985
5	nut cover cap M12

UNLESS OTHERWISE SPECIFIED:
 DIMENSIONS ARE IN MILLIMETERS
 WEIGHT ARE IN KILOGRAMM

	NAME	SIGNATURE	DATE	REVISION
DRAWN	M.Rebase		31.03.2022	
APPV'D				

PART NUMBER / DWG NO.:
MM118

DESCRIPTION:
**Playship NOA
 connecting flag to post**



MATERIAL:		A4
WEIGHT:	SCALE: 1:8	SHEET 34 OF 40

A

B

C

D

E

F

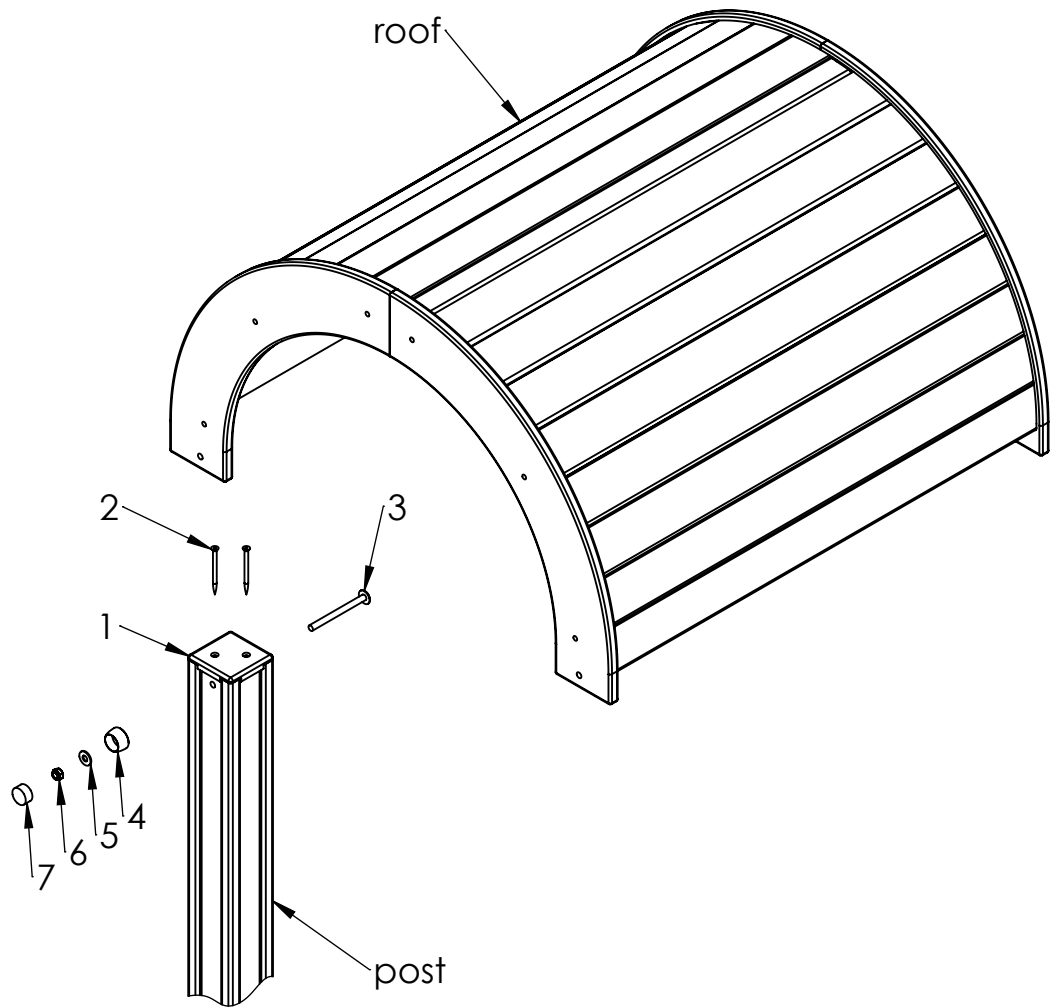

ITEM NO.	PART NUMBER
1	plastic cap 98x98
2	wood screw 6 x 90
3	bolt M10x120 DIN603
4	nut cover M12
5	washer M10 DIN9054
6	nut M10 DIN985
7	nut cover cap M12

UNLESS OTHERWISE SPECIFIED:
DIMENSIONS ARE IN MILLIMETERS
WEIGHT ARE IN KILOGRAMM

PART NUMBER / DWG NO.:

MM118

	NAME	SIGNATURE	DATE	REVISION
DRAWN	M.Rebase		31.03.2022	
APPV'D				

DESCRIPTION:

Playship NOA
connecting roof to post

MATERIAL:

A4

WEIGHT:

SCALE: 1:12

SHEET 35 OF 40



Tiptiptap OÜ

A

B

C

D

E

F

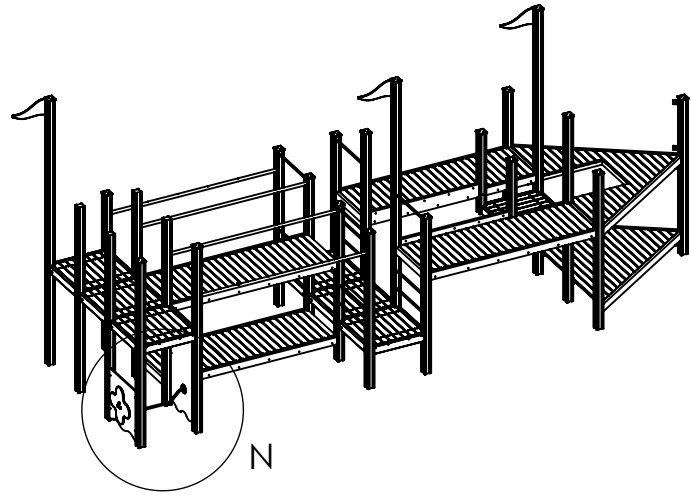

DETAIL N
step 1

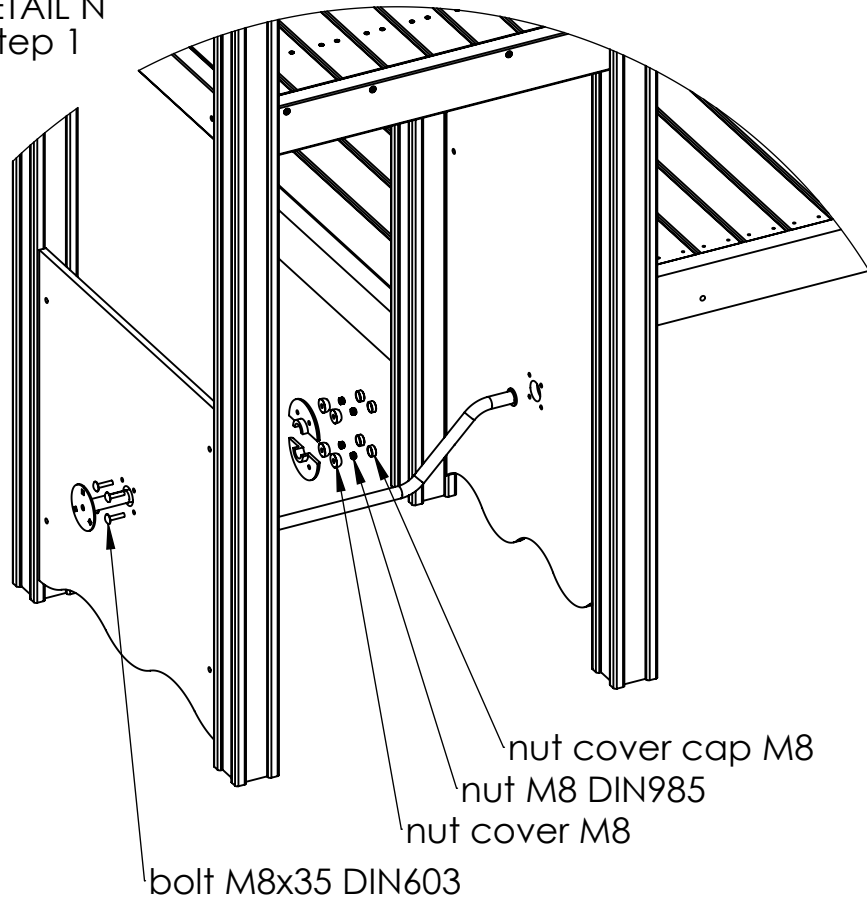

- nut cover cap M8
- nut M8 DIN985
- nut cover M8
- bolt M8x35 DIN603

UNLESS OTHERWISE SPECIFIED:
DIMENSIONS ARE IN MILLIMETERS
WEIGHT ARE IN KILOGRAMM

PART NUMBER / DWG NO.:

MM118

	NAME	SIGNATURE	DATE	REVISION
DRAWN	M.Rebase		31.03.2022	
APPV'D				

DESCRIPTION:

Playship NOA



Tiptap OÜ

MATERIAL:

A4

WEIGHT:

SCALE: 1:100

SHEET 36 OF 40

A

B

C

DETAIL N
step 2

- nut cover cap M8
- nut M8 DIN985
- nut cover M8
- bolt M8x30 DIN603

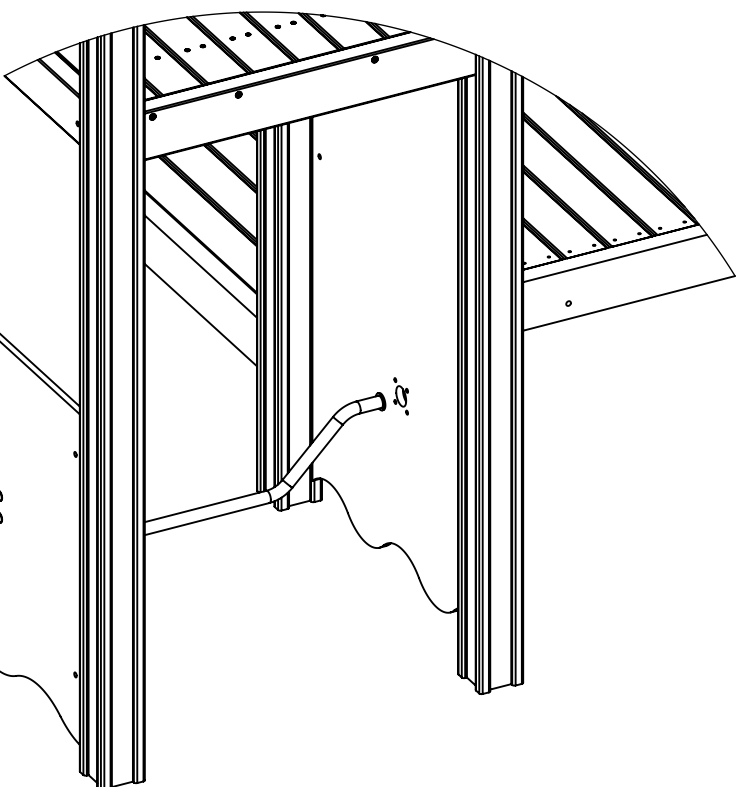

D

E

DETAIL N
step 3

- nut cover cap M8
- nut M8 DIN985
- nut cover M8
- bolt M8x45 DIN603

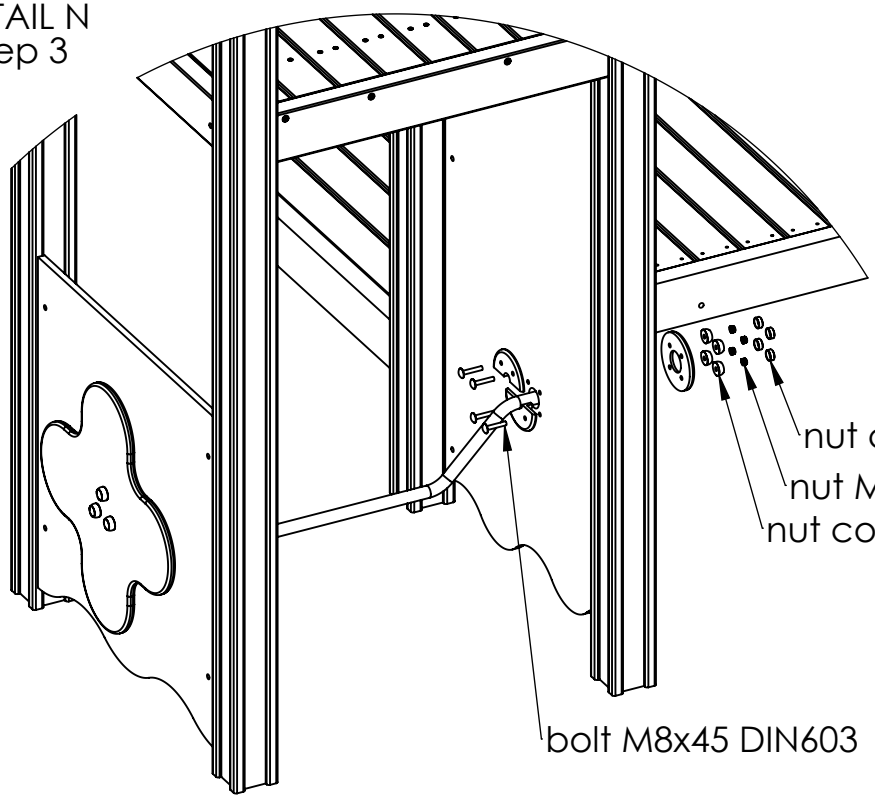

UNLESS OTHERWISE SPECIFIED:
DIMENSIONS ARE IN MILLIMETERS
WEIGHT ARE IN KILOGRAMM

PART NUMBER / DWG NO.:
MM118

	NAME	SIGNATURE	DATE	REVISION
DRAWN	M.Rebase		31.03.2022	
APPV'D				

DESCRIPTION:
Playship NOA

F



Tiptiptap OÜ

MATERIAL:		A4
WEIGHT:	SCALE: 1:100	SHEET 37 OF 40

A

B

C

D

E

F

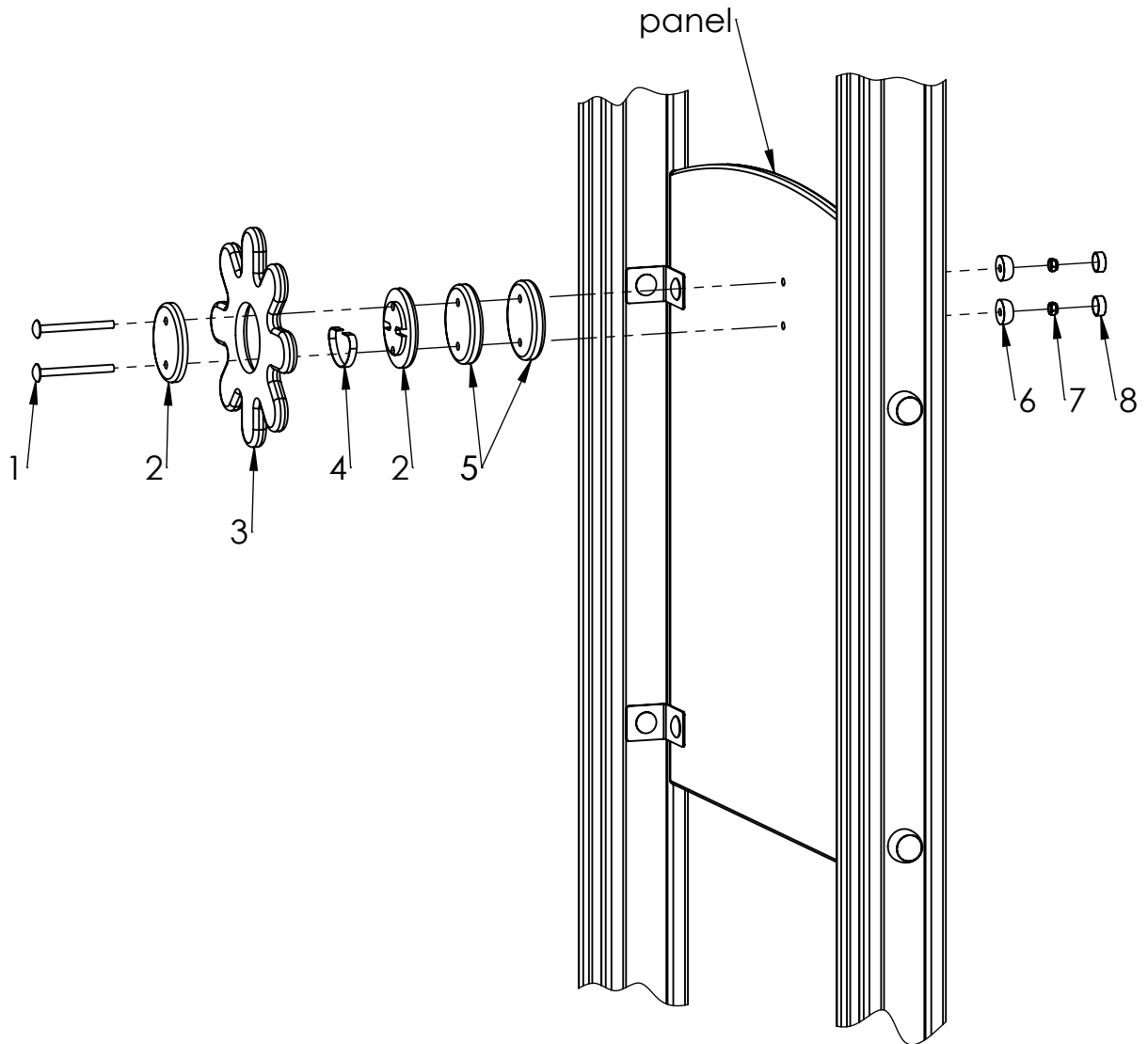

ITEM NO.	PART NUMBER
1	bolt M8x90 DIN603
2	disk 90mm for spring
3	captain wheel
4	spring for wheel
5	disk 90mm
6	nut cover M8
7	nut M8 DIN985
8	nut cover cap M8

UNLESS OTHERWISE SPECIFIED:
DIMENSIONS ARE IN MILLIMETERS
WEIGHT ARE IN KILOGRAMM

	NAME	SIGNATURE	DATE	REVISION
DRAWN	M.Rebase		31.03.2022	
APPV'D				

PART NUMBER / DWG NO.:

MM118

DESCRIPTION:

Playship NOA
connecting captain wheel to panel

MATERIAL:

A4

WEIGHT:

SCALE: 1:8

SHEET 38 OF 40



Tiptap OÜ

A

B

C

D

E

F

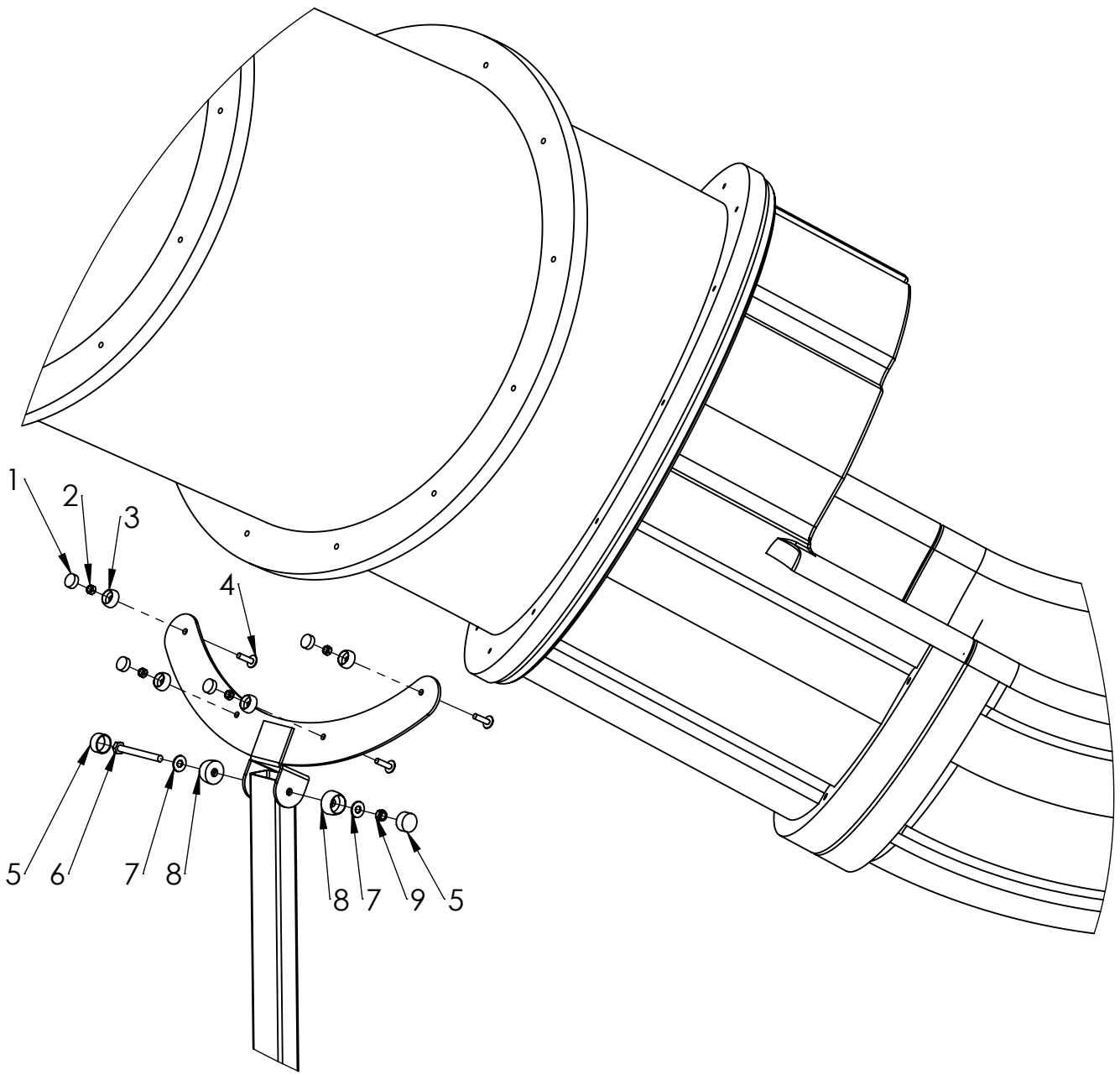

ITEM NO.	PART NUMBER
1	nut cover cap M8
2	nut DIN985 M8
3	nut cover M8
4	bolt DIN603 M8x30
5	nut cover cap M12
6	bolt M10x100 DIN931
7	Washer M10 DIN7349
8	nut cover M12
9	nut DIN985 M10

UNLESS OTHERWISE SPECIFIED: DIMENSIONS ARE IN MILLIMETERS WEIGHT ARE IN KILOGRAMM				
	NAME	SIGNATURE	DATE	REVISION
DRAWN	M.Rebase		31.03.2022	
APPV'D				

PART NUMBER / DWG NO.:	MM118
DESCRIPTION:	Playship NOA



MATERIAL:	A4
WEIGHT:	SCALE: 1:8
	SHEET 39 OF 40

A

B

C

D

E

F

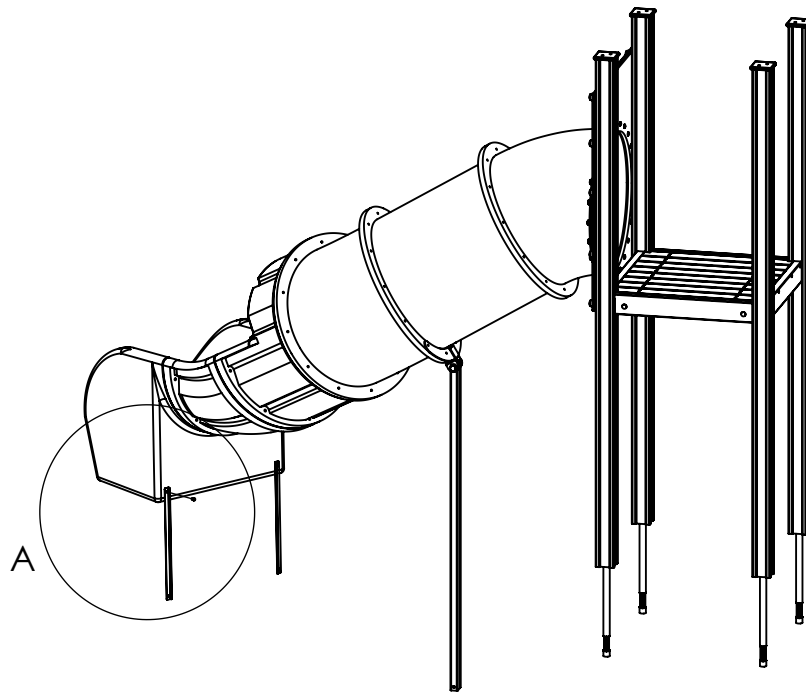

DETAIL A
SCALE 1 : 10

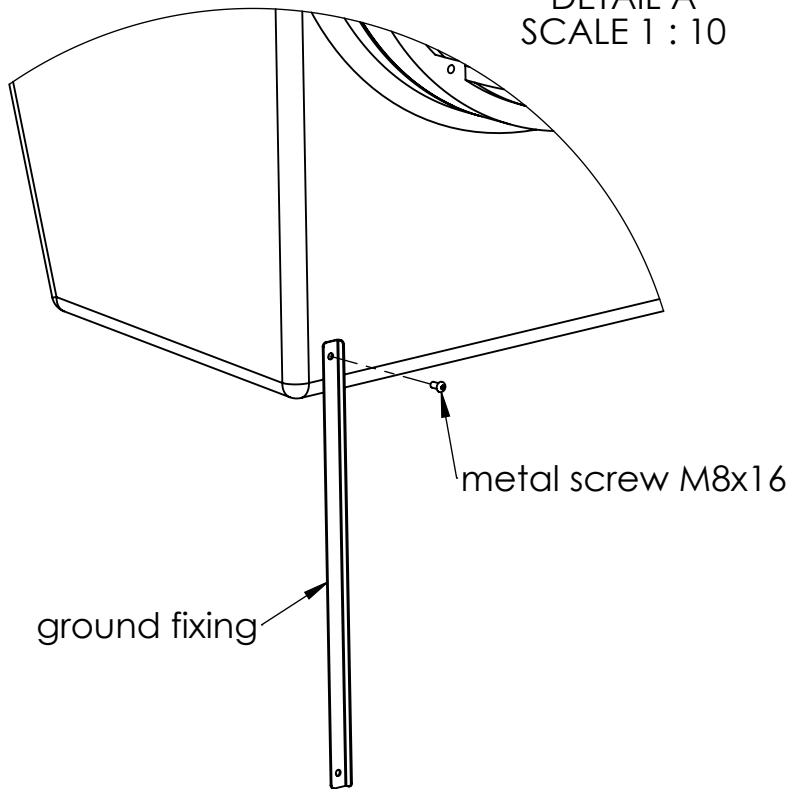

UNLESS OTHERWISE SPECIFIED:
DIMENSIONS ARE IN MILLIMETERS
WEIGHT ARE IN KILOGRAMM

PART NUMBER / DWG NO.:

MM118

	NAME	SIGNATURE	DATE	REVISION
DRAWN	M.Rebase		31.03.2022	
APPV'D				

DESCRIPTION:

Playship NOA



Tiptiptap OÜ

MATERIAL:

A4

WEIGHT:

SCALE: 1:8

SHEET 40 OF 40